

This vintage Hewlett Packard document was  
preserved and distributed by  
the

**HEWLETT  
PACKARD  
ARCHIVE**

Please visit us on the web!

**[WWW.HPARCHIVE.COM](http://WWW.HPARCHIVE.COM)**

Scanned by on-line curator: Tony Gerbic

**\*\* For FREE Distribution Only \*\***

**HEWLETT PACKARD**

**C O R P O R A T I O N**

# **212A**

**PULSE GENERATOR**

SERIALS PREFIXED : 419

**OPERATING AND SERVICING MANUAL**



**PRINTED 10-59**

OPERATING AND SERVICING MANUAL  
FOR

MODEL 212A  
PULSE GENERATOR  
Serials Prefixed: 419-

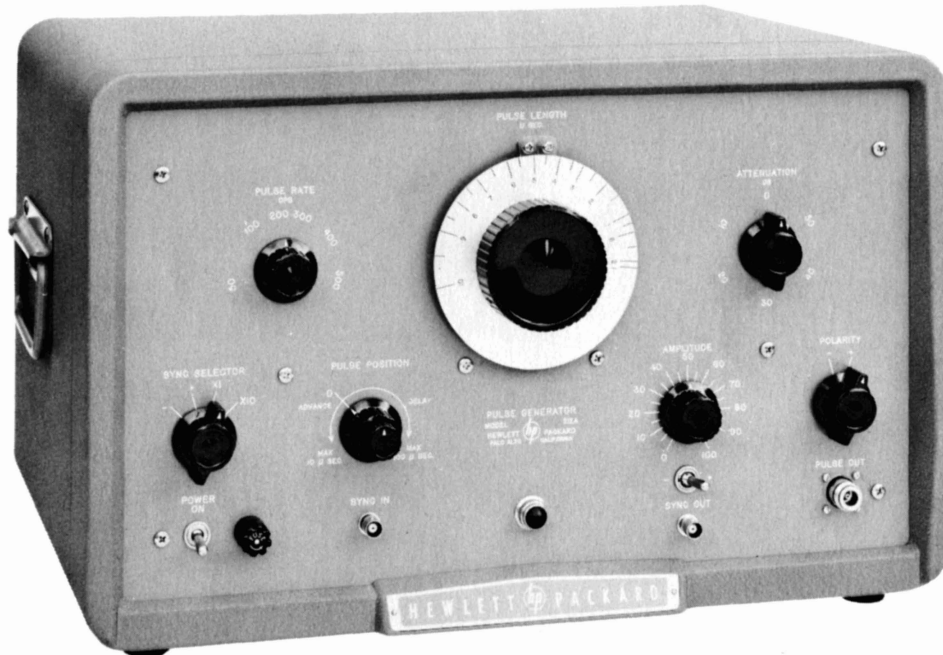

## SPECIFICATIONS

PULSE LENGTH:	At least 0.07 to 10 microseconds, continuously variable.
PULSE AMPLITUDE:	At least 50 volts peak into 50 ohm load (50 watts peak).
PULSE POLARITY:	Positive or Negative.
AMPLITUDE CONTROL:	(a) 50 db attenuator, variable in 10 db steps. (b) Continuously variable control with range of at least 10 db.
PULSE SHAPE:	(a) Rise and decay time approximately 0.02 microseconds (10% to 90%). (b) Crest variation less than $\pm 5\%$ of average peak amplitude.
JITTER:	Less than 0.01 microseconds.
INTERNAL IMPEDANCE:	50 ohms or less on either pulse polarity.
REPETITION RATE:	(a) Internal synchronization, 50 to 5,000 pps. (b) External synchronization, $\approx 2$ to 5,000 pps.
SYNC IN:	Positive or negative, 5 volts peak minimum.
SYNC OUT:	(a) 25 volts positive or 15 volts negative into 2,000 ohm load. (b) Duration, approximately 1 microsecond at half voltage points. (c) Rise time, approximately 0.25 microseconds.
PULSE POSITION:	(a) Delay, 0 to 100 microseconds after sync out pulse with repetition rate up to 2500 pps. (b) Delay, 0 to 50 microseconds after sync out pulse with repetition rate up to 5000 pps. (c) Advance, 0 to 10 microseconds after sync out pulse with repetition rate up to 5000 pps.
CONNECTORS:	(a) Main pulse, Type N. (b) Sync in, sync out, Type BNC.
POWER SUPPLY:	115/230 volts $\pm 10\%$ , 50/60 cps, 380 watts maximum.
DIMENSIONS:	Cabinet Mount: 20-3/4" wide, 12-3/4" high, 14-3/16" deep. Rack Mount: 19" wide, 10-1/2" high, 14-3/4" deep.
WEIGHT:	Cabinet Mount: 56 lbs., shipping weight approximately 76 lbs. Rack Mount; 50 lbs., shipping weight approximately 73 lbs.
ACCESSORIES AVAILABLE:	Ⓜ AC-16F Cable Assembly, Type N Male to Type N Male Fittings. Ⓜ AC-16K Cable Assembly, BNC to BNC. Ⓜ #17 End Frames, with handles for bench use, (for 212AR Rack Mount).

TABLE OF CONTENTS

		<u>Page No.</u>
Section I	GENERAL DESCRIPTION	
	1-1 General . . . . .	1-1
	1-2 Accessory Cables . . . . .	1-1
Section II	OPERATING INSTRUCTIONS	
	2-1 Inspection . . . . .	2-1
	2-2 Controls and Terminals . . . . .	2-1
	2-3 Automatic Overload Relay Protection . . . . .	2-2
	2-4 Operation . . . . .	2-2
	2-5 Waveshape of Output Pulse . . . . .	2-3
	2-6 Positive and Negative Pulse Output Levels . . . . .	2-4
	2-7 Operation of Pulse Length and Pulse Rate Controls . . . . .	2-4
	2-8 Operation of Pulse Position Control . . . . .	2-5
Section III	CIRCUIT DESCRIPTION	
	3-1 General . . . . .	3-1
	3-2 Rep. Rate MV . . . . .	3-1
	3-3 Delay MV and Blocking Oscillator . . . . .	3-1
	3-4 Pulse Position MV and Blocking Oscillator . . . . .	3-2
	3-5 Pulse Forming Thyatron V6 . . . . .	3-2
	3-6 Pulse Length MV and Blocking Oscillator . . . . .	3-2
	3-7 Pulse Terminating Thyatron V16 . . . . .	3-3
	3-8 Clipper Circuits . . . . .	3-3
	3-9 Output Amplifier . . . . .	3-3
	3-10 Power Supply . . . . .	3-3
Section IV	MAINTENANCE	
	4-1 Output Pulse Analysis. . . . .	4-1
	4-2 Adjustments . . . . .	4-3
	4-3 Servicing Negative High Voltage Supply (V4, V12, V14, etc.) . . . . .	4-5
	4-4 Thyatron Replacement . . . . .	4-5
	4-5 Replacement of Load Resistor R21 and R22 . . . . .	4-6
	4-6 Trouble Shooting Chart . . . . .	4-7
Section V	TABLE OF REPLACEABLE PARTS . . . . .	5-1

## SECTION I

### GENERAL DESCRIPTION

#### 1-1 GENERAL

The Model 212A Pulse Generator is a fundamental measuring instrument for determining the action of circuits under conditions of rapid change.

The pulse produced by this instrument has a short time of rise and decay with a flat top and minimum of overshoot. Either positive or negative pulses are available and the pulse shape is independent of the repetition rate, connected load, sync condition, supply voltages, and output attenuator setting. The pulse length is continuously variable from .07 to 10 microseconds.

This instrument is applicable to the testing of radar systems, nuclear counting circuits, television systems, response of video amplifiers, filters and band pass circuits and pulse modulation of UHF signal generators.

#### 1-2 ACCESSORY CABLES

AC-16K: RG-58/U 50 ohm coaxial cable terminated each end with UG-88/U Type BNC male connector. Overall length 48".

AC-16B: RG-58/U 50 ohm coaxial cable terminated on one end with UG-88/U Type BNC male connector and dual banana plug (3/4" center) on the other end. Overall length 45".

AC-16D: RG-58/U coaxial cable terminated one end only with UG-88/U Type BNC male connector. Overall length 44".

AC-16C: RG-9A/U 50 ohm coaxial cable terminated one end with UG-21B/U Type N male connector and UG-23B/U Type N female connector at other end. Overall length 72".

AC-16F: RG-9A/U 50 ohm coaxial cable terminated on each end with UG-21B/U Type N male connectors. Overall length 72".



SECTION II  
OPERATING INSTRUCTIONS

2-1 INSPECTION

Refer to the Warranty sheet in this manual.

2-2 CONTROLS AND TERMINALS

**PULSE OUT**

This terminal is a Type N jack located at the lower right corner of the front panel. It is the output connection for the main pulse.

**SYNC OUT**

This terminal is a BNC terminal on the lower right side of the panel. This terminal provides a voltage to synchronize an oscilloscope or other device for use with the Pulse Generator.

**+, -**

This toggle switch, on the panel above the SYNC OUT terminal, controls the polarity of the synchronizing voltage fed to the SYNC OUT terminal.

**SYNC IN**

The SYNC IN terminal is a BNC connector on the lower left side of the panel. A voltage can be fed into this terminal to trigger the pulse generating circuit.

**SYNC SELECTOR**

The SYNC SELECTOR knob selects two ranges of internally generated pulse rates, and also selects necessary circuitry for external synchronization from either positive or negative externally generated sync pulses.

**PULSE POSITION**

The PULSE POSITION control adjusts the timing between the MAIN PULSE OUTPUT and the SYNC OUTPUT pulse. Its main use is to position the main pulse on an oscilloscope screen when the oscilloscope has been synchronized with the SYNC OUT pulse.

**PULSE RATE**

The PULSE RATE control, located on the upper left hand side of the panel, adjusts the repetition rates of the pulse from 50 to 5000 cycles per second in conjunction with the X1 and X10 position of the SYNC SELECTOR switch.



#### PULSE WIDTH

The PULSE WIDTH control is the large dial at the center of the panel and controls the width of the MAIN OUTPUT pulse.

#### AMPLITUDE

The AMPLITUDE control gives a continuous variation of the MAIN OUTPUT pulse.

#### ATTENUATION

The ATTENUATION control, located on the right hand side of the panel, provides attenuation of the Main pulse in 10 db steps so that low levels of pulse output can be obtained.

#### POLARITY

The POLARITY control at the lower right hand side of the panel switches the polarity of the MAIN OUTPUT pulse from positive to negative.

#### FUSE

The fuseholder, on the panel next to the POWER ON switch, contains a 4 ampere cartridge fuse. A 2 ampere fuse should be used when the power transformer is connected for 230V operation. The fuse may be replaced by unscrewing the fuseholder cap and inserting a new fuse.

### 2-3 AUTOMATIC OVERLOAD RELAY PROTECTION

An overload relay is incorporated in the instrument to protect the  $\text{hp}$  45B thyatron if, for any reason, continuous plate current conduction occurs. Operation of the relay is indicated by a buzzing sound. If this occurs when the instrument is first turned on, it may indicate that there is insufficient warm-up and turning the SYNC SELECTOR to the + or - position without any external triggering for two or three minutes should then place the instrument in normal operating condition.

### 2-4 OPERATION

The Model 212A Pulse Generator is operated as follows:

1. Plug the power cable into a nominal 115V, 50 to 60 cycles power line and turn on the toggle switch. (The pilot lamp should light when the switch is on.)
2. Allow several minutes for the instrument to warm up with the SYNC SELECTOR in the + or - position and with no sync in. Although the unit can be used after 2 or 3 minutes of warm up, it is desirable to allow about ten minutes warm up time if possible.
3. Connect the equipment to be driven to the PULSE OUT terminal. This connection should be made, if possible, through a nominal

50 ohm cable.

NOTE

The output circuit of the Model 212A is terminated with approximately 50 ohms so termination of the output cable with 50 ohms is not absolutely necessary for many measurements. If the overall system is sensitive to frequencies on the order of 20 to 30 megacycles, the output cable should be terminated in a non-inductive 50 ohm load to prevent reflections from the load which may cause ringing. This is especially true when the ATTENUATION and OUTPUT controls are set for full output. Under these conditions the Model 212A OUTPUT source impedance is less than 50 ohms thus resulting in an imperfect output cable termination at the source end.

The SYNC OUT terminal may be connected to the synchronizing terminals on an oscilloscope and the polarity of the SYNC OUT signal may be switched to select the best performance. The SYNC SELECTOR should be set to either the X1 or the X10 position, and the PULSE RATE dial set to the desired repetition rate. The PULSE WIDTH dial may then be set to select the pulse width desired and the PULSE POSITION control is then adjusted until the pulse appears at the desired position on the oscilloscope screen. The amplitude of the pulse can be adjusted by means of the AMPLITUDE CONTROL and the OUTPUT ATTENUATOR to give the desired output level.

CAUTION

Do not set the PULSE POSITION delay to greater than 50 microseconds when a repetition rate of 5000 cps is used. Maximum delay of 100 microseconds may be used for repetition rates up to 2500 cps. Above 2500 cps the maximum delay must be decreased as the repetition rate is increased so as not to overload the tubes in the pulse position circuit.

2-5 WAVESHAPE OF OUTPUT PULSE

The output pulse from the Model 212A has extremely good waveshape and, in general, the waveshape is quite independent of the load and the operating conditions of the Pulse Generator. However, when the generator is operated at zero attenuation, with a length of cable between the generator and an unterminated load, reflections may occur due to the internal impedance of the generator being less than 50 ohms. This condition may be corrected by properly terminating the cable. As the attenuation is increased, the internal impedance approaches 50 ohms.

The waveshape is **best** with the AMPLITUDE control set to provide about 50 volts of output. As the amplitude is reduced with the AMPLITUDE control, the waveshape deteriorates slightly and, if the best waveshape is desired, it is preferable to reduce the output level with the attenuator and operate the AMPLITUDE control as close to the 50 volts position as possible.

The AMPLITUDE control is not calibrated, but, with no attenuation in the circuit, there will be at least 50 volts peak available from the output terminals into a 50 ohm load. On most units, the maximum position of the AMPLITUDE control will give appreciably more than 50 volts output. Unless this additional output is absolutely necessary, it is desirable to operate the unit with the AMPLITUDE control slightly below the maximum position. In some cases the pulse output waveshape will show a little deterioration with the AMPLITUDE control at full maximum.

## 2-6 POSITIVE AND NEGATIVE PULSE OUTPUT LEVELS

The positive and negative pulse outputs are adjusted to be approximately equal and either can be selected by means of the switch on the front panel. These outputs, however, cannot be expected to have exactly the same value and it is normal that there will be a little difference in amplitude between the positive and negative output position.

## 2-7 OPERATION OF PULSE LENGTH AND PULSE RATE CONTROLS

The pulse length is adjustable from less than .07 of a microsecond to 10 microseconds. This continuously adjustable feature in the Model 212A is convenient for a great many applications and is one of the useful features of this instrument. The generation of these very short, continuously adjustable pulses involves a differential operation whereby the difference between two larger time periods is used to control the actual time of the output pulse duration.

With this excellent flexibility in the control of the pulse output, there is a little sacrifice in absolute accuracy. In general the pulse length control can be expected to be correct within  $\pm 10$  percent except for very short pulse lengths where considerably more variation in the length may be obtained from time to time. Where accurate pulse lengths are necessary, it is desirable to use some sort of an auxiliary calibrating means to set the pulse length to the correct value. One of the main causes of variation in the pulse length is the variation in the characteristics of the hydrogen thyratron tubes used in the equipment. As tubes are changed in the equipment, some change in pulse length will be obtained, and also there may be some change in the pulse length calibration as the tubes age over a period of time. Controls are provided on the chassis just behind the main pulse dial so that the pulse length calibration can be reset

from time to time if necessary. See Section IV, Maintenance, regarding the adjustment of these controls.

The length of the main pulse is essentially independent of the other controls except that the pulse length will tend to change slightly as the repetition rate is changed especially above repetition rates of 1 kc.

The internal repetition rate generator is a multivibrator adjustable over the range from 50 to 5000 cycles/sec. Calibration of this control should, in general, hold within  $\pm 25\%$ , but when accurate repetition rates are desired, it is preferable to use an external oscillator to drive the pulse generator. The Model 212A can be synchronized from external pulses having at least a 5 volt amplitude and a rise time in the order of a microsecond or two. If it is desired to synchronize from a sine wave source, it is necessary to use a wave shaper of some sort to increase the rise time of the synchronizing voltage. The unit synchronizes very well from an  $\text{hp}$  Model 211A Square Wave Generator. Another typical waveshaper which may be used for a sine wave input is shown in Figure 2-1.

It is important that the Model 212A not be driven at a pulse rate in excess of 5000 cycles/sec. Performance at this end of the range is limited mainly by the duty cycle of the thyratrons. There is practically no limit to the repetition rate at the low frequency end provided the synchronizing pulses have a time-of-rise in the order of one or two microseconds.

Since the unit is limited by duty cycle at high repetition rates and long pulse widths, there is a tendency for the amplitude to be affected by repetition rates especially when the repetition rate is above 1000 cycles/sec and when the pulse width is at the maximum value. However, compensating circuits have been incorporated in the unit to minimize these amplitude variations and for most purposes they are not serious.

## 2-8 OPERATION OF PULSE POSITION CONTROL

The PULSE POSITION control is designed to adjust the main pulse timing around the SYNC OUT timing. This control will set the main pulse ahead of the sync out by approximately 10 microseconds or after the sync out by approximately 100 microseconds. This control is not calibrated as its main use is to position the main pulse on an oscilloscope screen. This pulse position will tend to be affected to some extent by the pulse rate. This condition is normal and should cause no serious difficulty under normal operating conditions. See important precaution given at the end of paragraph 2-4.

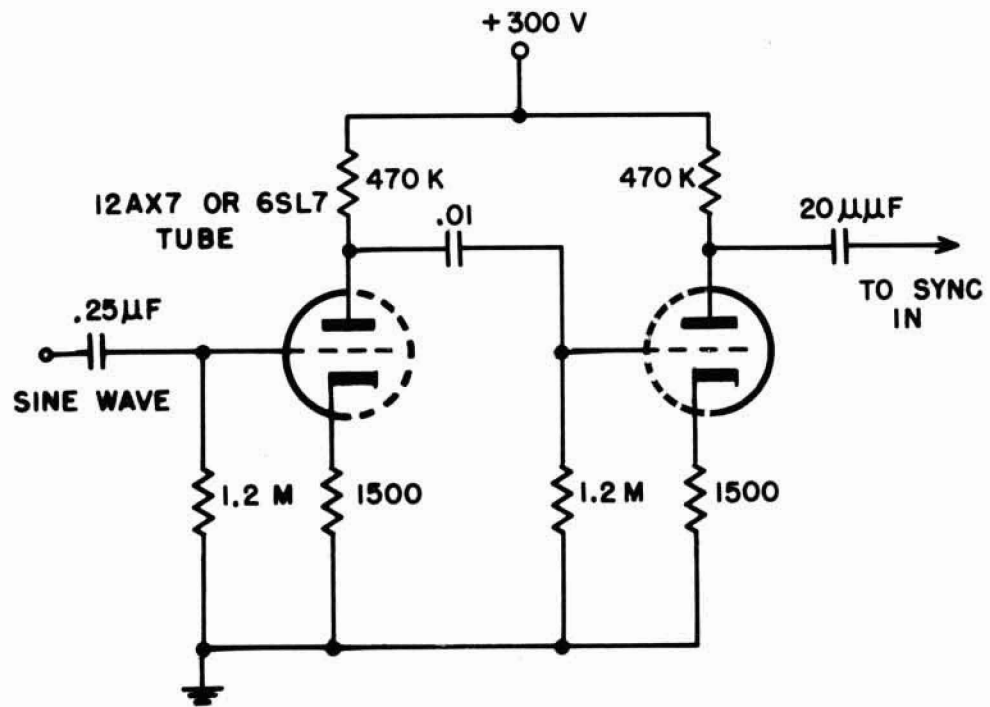

Schematic Wiring Diagram of a Typical Wave Shaper

Fig. 2-1

SECTION III  
CIRCUIT DESCRIPTION

3-1 GENERAL

The Model 212A Pulse Generator consists of three basic parts, the triggering circuits which are located in the front deck, the main pulse generating circuits, and the power supply which are located in the rear deck. The block diagram of the triggering and main pulse generating circuits are shown in Figure 3-1. All of the triggering circuits are located to the left of the thyratrons V6 and V16. This block diagram and the schematic wiring diagram will both be referred to in the following circuit description.

3-2 REP. RATE MV

This section of the circuit consists of an amplifier, phase inverter, and a multivibrator. The amplifier tube V103A and the phase inverter tube V103B in conjunction with switch S102A are used to deliver a negative pulse to the input of the multivibrator.

The repetition rate multivibrator consists of tube V104AB and may be operated either free running or triggered by an external pulse. In the free running condition it generates pulses at the repetition rate of 50-5000 pulses per second or in the externally synchronized condition it may be externally triggered up to 5000 pulses per second.

When the multivibrator is externally synchronized, it is biased so that it generates a pulse only when triggered by the external pulse.

The pulses generated by this multivibrator are supplied to the delay multivibrator and the pulse position multivibrator.

3-3 DELAY MV AND BLOCKING OSCILLATOR

Tube V101AB is employed as a "one shot" multivibrator. The pulse from the repetition rate multivibrator triggers the delay multivibrator to produce a positive 15 microsecond pulse which is inverted by V102A. The trailing edge of the 15 microsecond pulse then triggers the blocking oscillator.

The blocking oscillator tube V102B forms the sync out pulse which is supplied to the sync out terminals of the instrument through a polarity reversing switch.

### 3-4 PULSE POSITION MV AND BLOCKING OSCILLATOR

The pulse position multivibrator tube V105AB is also a one shot multivibrator which is triggered by the pulse from the repetition rate multivibrator. A positive pulse 2 to 112 microseconds in length is produced by this multivibrator. The duration of this pulse is controlled by the variable resistor R132.

The blocking oscillator tube V106B forms the pulse which is supplied to the pulse length multivibrator and the delay line. Following the blocking oscillator is a cathode follower tube V107B which couples the blocking oscillator to the delay line. In series with the grid of this tube is a crystal rectifier CR104 and a resistor R152 which prevent reflections from the delay line being fed to the blocking oscillator circuit due to the cathode to grid capacity of V107B.

### 3-5 PULSE FORMING THYRATRON V6

Tube V2, which is normally connected as a diode, and the charging choke L2 are used to charge the pulse forming line so that plate voltage is applied to the pulse forming thyatron V6. If for any reason the thyatron draws excessive current, then the relay REL-1 applies a large negative voltage to the grid of the tube V2 thereby stopping the flow of current to V6.

When the pulse forming line is charged, a pulse from the blocking oscillator and delay line will trigger the thyatron tube. Once the thyatron tube is fired, it will continue to carry current, irrespective of the grid voltage, until the conduction is quenched by means of the pulse forming line. The pulse forming line causes the plate voltage to fall to zero after 10 microseconds due to a reverse polarity transient which travels down to the open end of the line and is reflected back to the starting point. This action limits the tube conduction and forms a 10 microsecond pulse across the cathode resistor R13.

The damping diode tube V3 is used to damp out any negative overshoots.

### 3-6 PULSE LENGTH MV AND BLOCKING OSCILLATOR

The positive pulse from the blocking oscillator V106B is inverted by tube V107A. The negative pulse from V107A triggers the pulse length multivibrator consisting of V108A and V108B. The pulse length is varied by the PULSE LENGTH control (R142).

The trailing edge of the negative pulse from the multivibrator triggers the blocking oscillator V109A. The output of the blocking oscillator is passed on to the thyatron V16 through the cathode follower tube V109B.

### 3-7 PULSE TERMINATING THYRATRON V16

The pulse from tube V109B triggers the pulse terminating thyatron V16. When fired, this thyatron in conjunction with the discharge diode V8 presents a very low impedance to the pulse from the pulse forming thyatron V6 and causes a rapid fall of the pulse to form the trailing edge.

Additional direct current voltage is supplied to V16 by means of R28 and allows the pulse terminating thyatron to fire when the pulse length is set to a very low value. Tube V8 in conjunction with R10 and C24 allows the thyatron V16 to be extinguished at the end of the pulse cycle.

### 3-8 CLIPPER CIRCUITS

The pulse from the thyatron is sent through a series of three diode clippers and then to the output amplifier tube V11. Tube V7 is the first diode clipper. Tube V9 is the second and third diode clipper.

### 3-9 OUTPUT AMPLIFIER

The output amplifier tube V11 feeds the polarity switch where either a plus or minus pulse may be selected and applied to the attenuator. The attenuator is then used to reduce the pulse 10 db steps.

Intermediate values of amplitude may be selected by means of the AMPLITUDE control which has a continuous range of more than 10 db.

This control consists of two ganged variable resistors which vary the grid bias and plate voltage on the output amplifier tube V11 and the cathode voltage on the two clipper tubes V7 and V9.

In order to provide a more constant pulse output amplitude with changes in repetition rate and pulse width, a compensation circuit is incorporated in the unit. When the rate or pulse width is increased, a positive voltage is applied to the cathode of V15 through R51 which causes the voltage to the plate of the output tube and bias of the clippers to increase thereby compensating for the otherwise decrease in output amplitude when the rate or pulse width is increased.

### 3-10 POWER SUPPLY

The power supply circuits are conventional, and the direct current supply voltages are regulated either by glow discharge type regulator tubes (V4, V12, V14) or by electronic regulators (V10B, V17A, V17B). Tubes V10B and V17B are used to regulate the +300V supply. Tubes V15 and V17 regulate the voltage supplied to the clipper and output amplifier circuits.



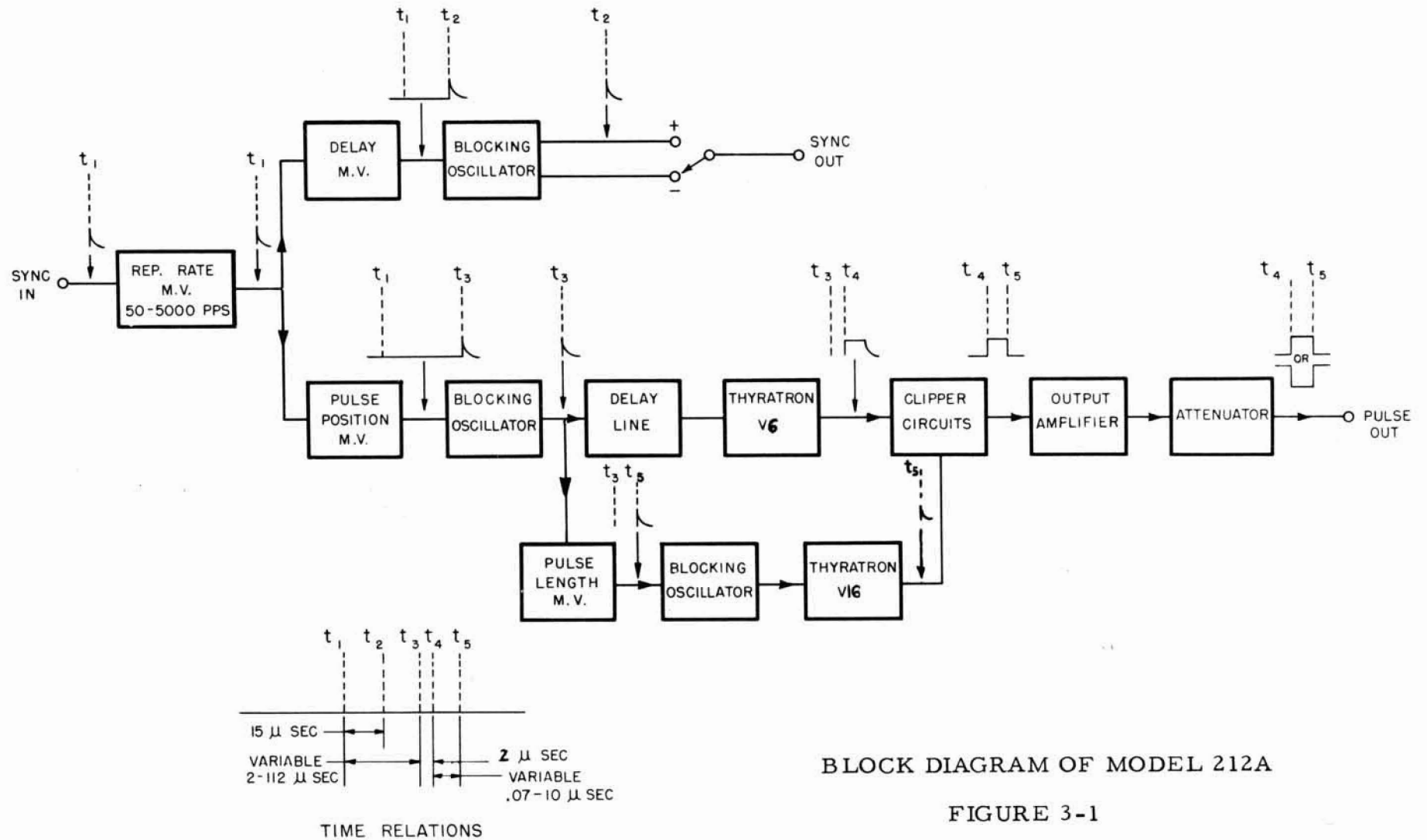

BLOCK DIAGRAM OF MODEL 212A

FIGURE 3-1

SECTION IV  
MAINTENANCE

4-1 OUTPUT PULSE ANALYSIS

The output pulse of the Model 212A Pulse Generator will be divided into three parts: the leading edge, the top or body, and the trailing edge. Each part is affected by different circuits. If a defect appears on a part of the output pulse, it will generally indicate the circuit at fault. Each part of the pulse is described separately and the list of symptoms in the trouble shooting chart follows the same general order.

Leading Edge -- V6, the 'start' thyatron, 'turns on' the output pulse. V107B triggers V6 and V6 forms the leading edge of the output pulse. Only the circuits of V6 and V107B are responsible for the condition of the leading edge of the output pulse. A defect that appears on the leading edge only, such as jitter and slowness, is the direct result of a defective tube, crystal diode, or other component in the circuits of V6 and V107B. See items 2, 3, and 4 of trouble shooting chart.

Overshoot -- Overshoot occurs to a greater degree on the leading edge of the pulse than on the trailing edge. Overshoot greater than specified is usually caused by leads used for external connections to the pulse generator.

Very minor overshoot coming from the pulse generator is caused by component construction, wiring and lead length within the instrument. V10A compensates for this overshoot on the leading edges of both negative and positive output pulses. This tube amplifies a portion of the rise time from thyatron V6 and couples it to the plate circuit of V11 for negative pulses and to the cathode circuit for positive pulses. The degree of compensation is controlled by adjustable ceramic capacitors C11 and C22. The setting of each capacitor affects that of the other. The final adjustment is accomplished by alternately adjusting the two capacitors while observing both positive and negative pulses. Adjust for optimum pulse shape. C11 is generally set near minimum capacity. C22 is used for a greater portion of the adjustment. See item 5 of the trouble shooting chart.

Top of Pulse -- When V6 is triggered, it generates a pulse limited in length by the time plate voltage supplied to this tube. To protect V6, the supply is constructed to momentarily stop power delivery approximately 11 microseconds from the time V6 fires. V6 is then extinguished and will not fire until re-triggered.

The pulse generated by V6 is very coarse and contains peaks in excess of 500 volts. Clippers V7 and V9 clip the amplitude to between 250 and 350

volts depending upon setting of the AMPLITUDE control. A flat-top pulse is now formed for application to the output amplifier V11. V11 is biased well beyond cutoff. As a result of the high bias voltage only the top portion of the clipped pulse generated by V6 is passed through V11. The very high bias on V11 removes unwanted signals of low amplitude that would otherwise appear on the baseline following the output pulse. See items 24 and 25 in trouble shooting chart.

The body of the final output pulse depends upon sufficient power from the high voltage supply to maintain high initial pulse amplitude. A droop in the pulse body generally indicates a defective component in the high-voltage supply. See item 6 of trouble shooting chart.

If the pulse contains peaks or humps above the normal level of the top, it would indicate ineffective clipping, see items 7 and 8 of trouble shooting chart. When the top has a gradual rise or drop, the correction may be a matter of adjustment and is covered in item 11 of the trouble shooting chart.

Trailing Edge -- V16 the 'stop' thyratron, 'turns off' the output pulse. When V16 is triggered, it forms the trailing edge of the pulse. The trigger pulse for the stop tube is developed by the circuits of amplifier 107a, multivibrator V108 and blocking oscillator V109a. The condition of the trailing edge is the result of all these circuits, plus V8 which is in series with 'stop' thyratron V16. The effects of these circuits can appear only on the trailing edge of the output pulse. See items 13 and 14 of trouble shooting chart.

"Both"Edges of Output Pulse -- If a trouble such as 'jitter' appears on both leading and trailing edges of the output pulse, the defect is generally in a circuit which affects both start and stop thyratrons simultaneously. All circuits preceding V107b, (V101 through V106b) affect both leading and trailing edges and do not affect one edge without affecting the other.

Pulse Length -- A change in pulse length caused by an increase or decrease in rate is generally due to one of the thyratrons. In some thyratrons there is a very small time lapse between the time the tube is triggered and the time the gas is fully ionized. The degree of time lapse depends on the duty cycle. This characteristic causes the pulse length to vary with rate. Generally, the time lapse increases with an increase in duty cycle. If the start tube has this characteristic, an increase in pulse rate will cause the output pulse to shorten. If the stop tube has this characteristic, the output pulse will lengthen with an increase in rate. See item 17 of trouble shooting chart.

High pulse rates tax both thyratrons to a greater degree than low rates. The symptoms of a failing thyratron therefore become more noticeable at higher pulse rates.

The greatest duty cycle for the stop thyratron, V16, occurs at maximum pulse rate and minimum pulse length. At that time it is conducting for the longest period of time. Under these conditions the stop thyratron will be most subject to jitter and slowness.

Microphonics -- Microphonics usually appear as a small jump in pulse position. Multivibrator tubes V101 and V105 are particularly subject to microphonics. When changing V101 and V105, it may be necessary to try several new tubes to obtain one which is not microphonic and which gives the required advance and delay. A small jump in the trailing edge only would indicate that V108 is microphonic.

A quick operational check for 12AU7 tubes can be made by exchanging with a 12AU7 not in a critical circuit, any position other than V101 or V105.

Interference Through Power Line -- Interference through the power line can occur when instruments on the line are not filtered or if transformers connecting to the line do not have shields between the primary and secondary windings. The interference may appear in various forms. A visual indication may be seen when viewing very low amplitude pulses on a very high sensitivity oscilloscope. The interference will cause ringing at the leading and trailing edges of the pulse.

In some models of the 212A Pulse Generator the filament transformer was constructed without an internal shield. Some of these models contained a line filter which is not shown in the schematic diagrams. If an instrument is known to cause interference through the power line, the line filter circuit shown at the rear of the manual should be added.

## 4-2 ADJUSTMENTS

Pulse Length Calibration -- The PULSE LENGTH dial is hand calibrated to the potentiometer in the pulse length multivibrator circuit. Composition potentiometers vary greatly in taper and can change taper after use. The calibration of the PULSE LENGTH dial will be only approximately correct after the potentiometer has been replaced or has aged. An external time standard is necessary where high accuracy is required.

Following replacement of a component within the circuits V108 the calibration of the PULSE LENGTH dial should be checked. If necessary, the dial calibration may be adjusted for greater accuracy as follows:

1. With pulse generator connected to a calibrated oscilloscope, set the PULSE LENGTH dial to 10.
2. If necessary, adjust C128 to obtain a pulse length of exactly 10 microseconds.

3. Set PULSE LENGTH dial to .1.
4. If necessary, adjust R143 to obtain a pulse length of .1 microsecond.
5. Check accuracy of other points on dial. The dial may be slipped on the shaft and the above adjustments refined for greatest overall accuracy.
6. If unable to bring close enough, particularly following replacement of R142, recalibration of a new dial will be required.

Pulse Rate Calibration -- The PULSE RATE dial is used only for approximate setting of the repetition frequency and its calibration is not meant to have high accuracy. Adjust as follows:

1. With the equipment operating set SYNC SELECTOR switch to the X10 position and the PULSE RATE dial to maximum clockwise position.
2. Adjust R124 to obtain a pulse rate of 5000 to 5200 pps.
3. With PULSE RATE control unchanged set SYNC SELECTOR switch to the X1 position.
4. Adjust R121 to obtain a pulse rate of 520 pps. The settings of R124 and R121 are interdependent. Steps 2 and 4 must be repeated until the desired maximum pulse rates are obtained on both the X1 and X10 ranges.
5. Set PULSE RATE dial and SYNC SELECTOR switch to obtain a repetition rate of 1000 pps. Loosen set screw in dial and set to read "100". Tighten set screw lightly.
6. Check other points on the dial for accuracy of calibration. Readjust the above settings for best compromise on overall accuracy.

Pulse Position Calibration -- No adjustments are provided for setting the PULSE POSITION control. The position of "0" delay or advance is obtained by slipping the dial on the shaft to the correct position.

The maximum delay obtainable depends on V105.

The maximum advance obtainable depends on V101.

#### NOTE

At maximum rate do not use delays in excess of 50 microseconds, or, at max. delay do not use rates in excess of 2500 pps.

Power Supply Adjustment -- The D. C. output voltage of the regulator is adjusted by varying the grid bias of the amplifier tube with a potentiometer. Following service to the power supplies, three checks must be made as follows:

1. Check voltage between the cathode (pin 6) of V17 and ground. If necessary, adjust R33 to obtain 300 volts.
2. Check voltage between the center terminal of R110 and ground. If necessary, with instrument not pulsing, adjust R110 to obtain -28 volts at the center terminal.
3. Check maximum output pulse amplitude. If necessary, adjust R35 to obtain 60 volt pulse amplitude.

Relay Adjustment -- (Normally not required for life of relay)

1. Open circuit between relay and R28.
2. Insert milliammeter between relay and pin 5 of V17.
3. Set pulse rate dial at max. and sync selector to X10.
4. Control current through relay by varying R124. Set relay to actuate at 50 ma by adjusting tension on armature springs.
5. Reconnect R28 to relay and reset pulse calibration.

#### 4-3 SERVICING NEGATIVE HIGH VOLTAGE SUPPLY (V4, V12, V14, Etc.)

Following replacement of parts within the negative high voltage supply the current through the voltage regulator tube V4 should be measured at line voltages of 105 and 125 volts. If necessary, the value of R1 may be padded to obtain not less than 10 milli-amperes with a line voltage of 105 volts and not more than 30 milli-amperes with a line voltage of 125 volts.

#### 4-4 THYRATRON REPLACEMENT

V6 and V16 are critical tube positions. To quickly check a thyatron suspected of being faulty interchange V6 and V16 to see if the observed symptoms change as the tubes are exchanged. For example, if jitter is observed on the trailing edge of the pulse, but not on the leading edge, exchange V6 and V16. If jitter now appears on the leading edge and not on the trailing edge as it did before, the trouble is clearly a result of the thyatron now in the V6 position. However, if the jitter remains on the trailing edge in spite of the tube change, the trouble is most likely in the circuits associated

When replacing V6 and V16, the replacement tube should be a type HP45B. The HP45 is specially manufactured for use in the Model 212A. If a standard 3C45 thyratron is used for replacement, aging will be necessary (see following paragraphs). It may be expected that a high percentage of standard 3C45 replacements will not successfully operate in this instrument. If a type HP45B is used, aging and tube selection should not be required.

When a 3C45 is used to replace a thyratron in the Model 212A Pulse Generator, proceed as follows:

1. Remove screen cover from the back of the instrument.
2. Release tube clamp and remove suspected thyratron. Place asbestos cover over replacement tube, place tube in socket and tighten clamp. On V6 also change plate shield to new tube.
3. Prepare to operate instrument. Set the SYNC SELECTOR switch to the - or + position so the instrument will not pulse when turned on. Set RATE control to minimum and the PULSE LENGTH control to 10 microseconds.
4. Turn instrument on and allow to heat for approximately ten minutes.
5. Set the SYNC SELECTOR switch to the X1 position. The relay may chatter for up to one minute and stop.
6. Increase RATE control and decrease PULSE LENGTH control until a maximum rate and minimum pulse length are obtained without relay chatter. This process may take an hour or more for some tubes.
7. Allow instrument to run at maximum rate and minimum length for approximately twenty-four hours. Observe output pulse. If pulse is unsatisfactory due to excessive jitter or slow rise or decay time, allow to run an additional twenty-four hours. Again observe pulse. If, after seventy-two hours of operation, the output pulse is still unsatisfactory and the thyratron is known to be the cause of the trouble, try another replacement thyratron.

#### 4-5 REPLACEMENT OF LOAD RESISTOR R21 AND R22

The resistors used for R21 and R22 may be any of several different types. A replacement resistor need not be identical, however, it must be non-inductive such as the deposited-carbon or metalized-film types. The resistor must have not less than a 5 watt dissipation rating, and should be within 5% of the value shown on the schematic diagram.

Parallel combinations of lower wattage resistors may be used successfully, however, lead and component length should be kept as short as possible.

When R21 is replaced by a single, cylindrical resistor, the replacement should be mounted so its axis is horizontal and parallel to the side of the instrument.

Replacement resistors for R21 and R22 may be procured from Hewlett-Packard Company. When possible, parts order should be accompanied by serial number of instrument to be serviced.



#### 4-6 TROUBLE SHOOTING CHART

The following trouble shooting chart is a list of observed symptoms. The solutions for each symptom are listed in order of expected probability. Each suggested remedy is followed by a note giving cautions and checks that should be made following replacement of a component. When no caution or check is listed, the component may be replaced without other than normal precautions. Dial calibrations will usually be inaccurate following a tube change within a multivibrator circuit. If a tube is removed for checking and is not found faulty, it should be returned to the same socket.



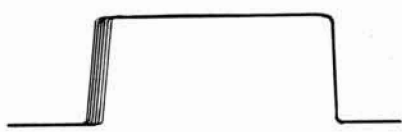
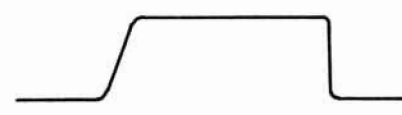





TROUBLE SHOOTING CHART FOR MODEL 212A PULSE GENERATOR

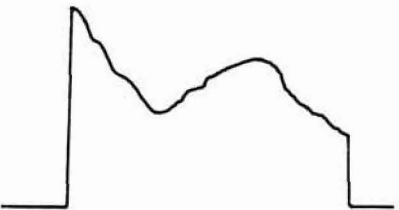

SYMPTOM	DEFECTIVE COMPONENT	SUGGESTIONS - CAUTIONS - CHECKS - ETC.
<p>1. RELAY CHATTER</p>	<p>V6</p> <p>V104</p> <p>V105</p> <p>V106</p> <p>SHORTED CAPACITOR IN PULSE LINE</p>	<p>Replace V6 or interchange V6 and V16. Check PULSE LENGTH calibration and pulse shape.</p> <p>Replace V104. Check PULSE RATE calibration.</p> <p>Replace V105. Check maximum pulse delay.</p> <p>Replace V106.</p> <p>Replace defective capacitor. Check maximum pulse length.</p>
<p>2. JITTER ON LEADING EDGE ONLY OF OUT- PUT PULSE</p> 	<p>V6</p> <p>V104 ) CR104)</p>	<p>Replace V6. Check rise time and PULSE LENGTH calibration.</p> <p>Not likely to occur.</p>
<p>3. SLOW RISE TIME</p> 	<p>V6</p>	<p>Replace V6. Check rise time and PULSE LENGTH calibration.</p>
<p>4. NO PULSE (SYNC OUT PULSE AVAILABLE)</p>	<p>V6</p>	<p>Replace V6 or exchange V6 and V16 for trial. Check pulse shape and length.</p>

	V1 V2 L3 V105 V106 C135, C138	Replace V1. Replace V2. Replace L3. Replace V105. Check maximum delay and 'Zero' position of control. Replace V106. Replace defective capacitor in delay line.
5. OVERSHOOT ON LEADING EDGE 	V3 V9 C31	V3 may effect the very small spike on top of leading edge. V9 may effect the 1/2 to 1 microsecond hump on top following leading edge. C31 may be as high as 30 $\mu\text{mf}$ to reduce various forms of overshoot.
6. DETERIORATION OF PULSE TOP 	V1 V2 V6 RELAY L2 L3 V104	Replace V1. Replace V2. Check V6. Clean contacts on relay RL-1. Replace L2.) ) Not likely to occur Replace L3.) Check pulse rate calibration, may be free running at very high rate.

TRUBLE SHOOTING CHART (Cont'd)

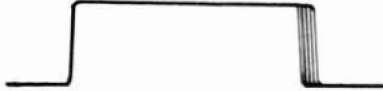

SYMPTOM	DEFECTIVE COMPONENT	SUGGESTIONS - CAUTIONS - CHECKS - ETC.
<p>7. UNCLIPPED PULSE, HIGH AMPLITUDE PEAKS</p> 	<p>R30 V7 V9</p>	<p>R30 burns open if V7 or V9 shorts, resulting in an unclipped output pulse. Replace defective V7 or V9 and R30.</p>
<p>8. HUMPED TOP OF PULSE AT RATED OUTPUT</p> 	<p>V7</p>	<p>Replace V7. Check flatness of pulse top.</p>
<p>9. ENLARGED TRACE OF TOP OF PULSE</p> 	<p>V17  V15  V11</p>	<p>Replace V17. Check regulated voltage per instruction book.</p> <p>Any cause of high ripple from V17A can have this effect.</p> <p>Replace V15. Check regulated voltage per instruction book.</p> <p>Replace V11.</p>

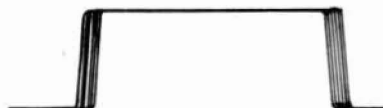
<p>10. TOP OF PULSE ROLLS OFF PREMATURELY BETWEEN 1 and 6 <math>\mu</math>seconds</p> 	<p>C135) C136) C137) C138)</p>	<p>Replace defective capacitor in pulse delay line.</p>
<p>11. EXCESSIVE SLOPE ON TOP OF PULSE</p> 	<p>R30  V11 C5</p>	<p>Pad value of R30 to give optimum pulse level for both low and high rates. Value varies between 50 and 100 ohms.</p> <p>Replace V11) occurs with Replace C5 ) old components</p>
<p>12. VARIATION OF PULSE AMPLITUDE WITH CHANGE IN RATE OR LENGTH</p> 	<p>V17  V15  R51</p>	<p>Replace V17. Check maximum positive pulse amplitude.</p> <p>Replace V15. Check maximum positive pulse amplitude.</p> <p>Adjust value of R51 to give minimum amplitude variation with changes in rate.</p>

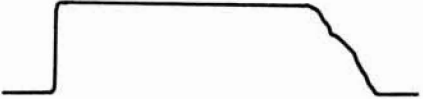
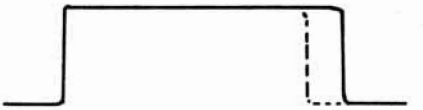
SYMPTOM	DEFECTIVE COMPONENT	SUGGESTIONS - CAUTIONS - CHECKS - ETC.
<p>13. JITTER ON TRAILING EDGE ONLY OUTPUT PULSES</p> 	<p>V16</p> <p>V108</p> <p>V8</p> <p>CR105</p> <p>CR106</p>	<p>Replace V16. Check leading edge of output pulse and PULSE LENGTH calibration.</p> <p>Replace V108. Check PULSE LENGTH calibration.</p> <p>Replace V8, check trailing edge of output pulse.</p> <p>Replace CR105.</p> <p>Only as last resort change this crystal as it may require calibration of another PULSE LENGTH dial.</p>
<p>14. SLOW DECAY TIME</p> 	<p>V16</p> <p>V8</p>	<p>Replace V16 and check trailing edge of output pulse and PULSE LENGTH calibration.</p> <p>Replace V8 and check trailing edge of output pulse and PULSE LENGTH calibration.</p>
<p>15. JITTER ON BOTH EDGES OF OUTPUT PULSE</p> 	<p>V101</p> <p>V105</p> <p>V104</p> <p>V106</p> <p>C103</p>	<p>Replace V101. Check zero and maximum pulse advance and microphonics.</p> <p>Replace V105. Check zero and maximum pulse delay and microphonics.</p> <p>Replace V104. Check PULSE RATE calibration.</p> <p>Replace V106.</p> <p>Coupling capacitor C139 (C103) may be connected in two different positions. Either position may be used. (See schematic diagrams).</p>

		<p>The best position for a particular instrument is the one which gives least jitter. If plate to plate coupling is used, C103 must be approximately 50 <math>\mu\mu\text{fd}</math>. If plate to cathode coupling is used, C103 must be 30 <math>\mu\mu\text{fd}</math>.</p>
	<p>CR102</p> <p>CR103</p>	<p>Replace CR102. Check maximum pulse delay.</p> <p>Replace CR103.</p>
<p>16. NO LENGTH CONTROL, PULSE ROLLS OFF AT 10.5 TO 11 <math>\mu\text{secs}</math>.</p> 	<p>V16</p> <p>V8</p> <p>V108</p> <p>V109</p> <p>V107</p>	<p>Replace V16. Check trailing edge of output pulse and PULSE LENGTH calibration.</p> <p>Replace V8. Check trailing edge of output pulse.</p> <p>Replace V108. Check PULSE LENGTH calibration.</p> <p>Replace V109.</p> <p>Replace V107.</p>
<p>17. DRIFT OF PULSE LENGTH FOLLOWING CHANGE IN PULSE RATE</p> 	<p>V6</p> <p>V16</p> <p>V108</p> <p>V109</p> <p>V8</p> <p>V107</p> <p>CR106</p> <p>CR105</p>	<p>Replace V6. Check rise time and PULSE LENGTH calibration.</p> <p>Replace V16. Check trailing edge of output pulse and PULSE LENGTH calibration.</p> <p>Replace V108. Check PULSE LENGTH calibration.</p> <p>Replace V109.</p> <p>Replace V8. Check trailing edge of output pulse.</p> <p>Replace V107. Check PULSE LENGTH calibration.</p> <p>Only as last resort replace this crystal as it may require calibration of a new PULSE LENGTH dial.</p> <p>Replace CR105.</p>

SYMPTOM	DEFECTIVE COMPONENT	SUGGESTIONS - CAUTIONS - CHECKS - ETC.
18. NO PULSE VISIBLE - TRIGGER PULSE VISIBLE  	V11 or power source for V11  R21  R22	Replace V11. Check maximum pulse amplitude. Replace defective component in power supply. Check maximum pulse amplitude and regulated supply voltage output per instruction manual.  Replace R21.  Replace R22.
19. AMPLITUDE OF NEG PULSE HIGHER THAN THAT OF POSITIVE PULSE	R22 In instruments having two parallel 100 ohm resistors for R22, check value of resistance	Replace defective resistor.
20. NO SYNC OUT PULSE	V102  V101  CR101  T101  S101 switch circuitry, shielded cables, etc.	Replace V102.  Replace V101. Check zero and maximum advance and microphonics.  Replace CR101. Check SYNC OUT pulse.  Check winding continuity of T101. Following replacement, check SYNC OUT pulse shape.  Check continuity and resistance to ground at points in sync output circuit.
21. INSUFFICIENT PULSE ADVANCE	V101	Replace V101. Check maximum advance obtainable, position of 0 advance on PULSE POSITION control and microphonics.





<p>22. INSUFFICIENT PULSE DELAY</p>	V105	<p>Replace V105. Check maximum pulse delay, position of '0' delay on PULSE POSITION control and microphonics.</p>
<p>23. INSUFFICIENT PULSE AMPLITUDE</p>	R35	<p>With AMPLITUDE control set to maximum, adjust R35 to give 60 volt output pulse.</p>
<p>24. HUMP ON BASELINE FOLLOWING AND ATTACHED TO OUTPUT PULSE</p> 	V11	<p>Replace V11.</p>
<p>25. HUMP ON BASELINE FOLLOWING AND DETACHED FROM OUTPUT PULSE</p> 	V6	<p>Replace V6. Check leading edge of output pulse and PULSE LENGTH calibration.</p>
<p>26. INACCURATE RATE CALIBRATION</p>	R125	<p>Tolerances of high resistance potentiometers are wide. The potentiometer selected will determine calibration accuracy.</p>
<p>27. RINGING ON BASELINE, FOLLOWING REPLACEMENT OF TRANSFORMER T103</p> 	T103	<p>Install 220 ohm, 1/2 watt resistor in series with grid of V16.</p>





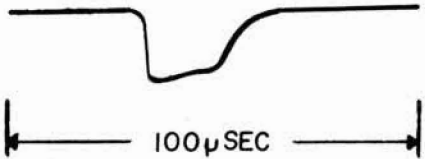











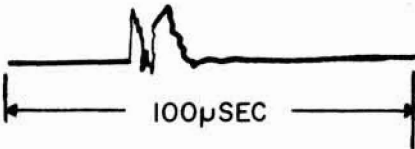

WAVEFORM DATA

The following waveforms may be observed at various points throughout the circuits. The points selected are those most useful and provide a very nearly complete picture of signal process from pulse initiation to pulse completion. Small variations in pulse shape may be expected, particularly with degree of overshoot, and depending on oscilloscope sweep speed used. The newer type pulse transformers used in instruments following serial 1439 develop waveshapes similar to, but not identical with, the waveshapes produced by the earlier pulse transformers.

The leading or trailing edges of the observed pulses are the actual triggering devices, not the bodies. Pulse timing multivibrators, V101, V105 and V108 are 'one shot' types whose pulse length (time from leading to trailing edge) is the time lapse desired. A leading edge is simultaneous with the trigger pulse from the preceding circuit. The trailing edge becomes the trigger pulse for the following circuit.

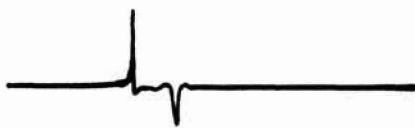
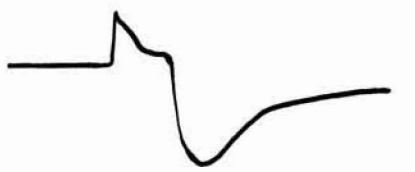
	POINT OF MEASUREMENT	APPROX. VOLTAGE	$\mu$ SEC. LENGTH	WAVEFORM
1.	Pin 6 of V104b	260V-	100	
2.	Pin 1 of V101a	126V-	100	
3.	Pin 6 of V101b	76V+	100	
4.	Pin 1 of V102a	170V-	100	
5.	Pin 7 of V102b	78V+	100	

	POINT OF MEASUREMENT	APPROX. VOLTAGE	$\mu$ SEC. LENGTH	WAVEFORM
6.	Pin 6 of V102b	162V-	100	
7.	SYNC OUT (positive)	58V+	10	
8.	C118, output side	121V-	100	
9.	Pin 1 of V105a	84V-	100	
10.	Pin 6 of V105b	76V+	100	
11.	Pin 1 of V106a	162V-	100	
12.	Pin 7 of V106b	70V+	100	
13.	Pin 6 of V106b	185V-	100	
14.	Pin 2 of V107b	350V+	100	

	POINT OF MEASUREMENT	APPROX. VOLTAGE	$\mu$ SEC. LENGTH	WAVEFORM
15.	Delay line, input	420V+	100	
16.	Delay line, output	480V+	100	
17.	Plate cap of V6	-900 to -1500 total volts.	100	
18.	Pin 2 or 4 of V6	500V+	100	
19.	Pin 7 of V10a	280V+ 100V-	10	
20.	Pin 7 of V107a	59V+	10	
21.	Pin 6 of V107a	216V-	10	
22.	Pin 2 of V108a	34V-	10	
23.	Pin 6 of V108b	112V-	10	

	POINT OF MEASUREMENT	APPROX. VOLTAGE	$\mu$ SEC. LENGTH	WAVEFORM
24.	Pin 2 of V109a	66V+	10	
25.	Pin 1 of V109a	160V-	10	
26.	Pin 7 of V109a	218V+	10	
27.	Plate cap of V16	345V+	100	
28.	Pins 1, 2, 5 and 6 of V8	380V+	100	
29.	Pin 1 of V11	350V+	100	
30.	Pins 3 and 6 of V11 (positive pulse output)	50V+	100	

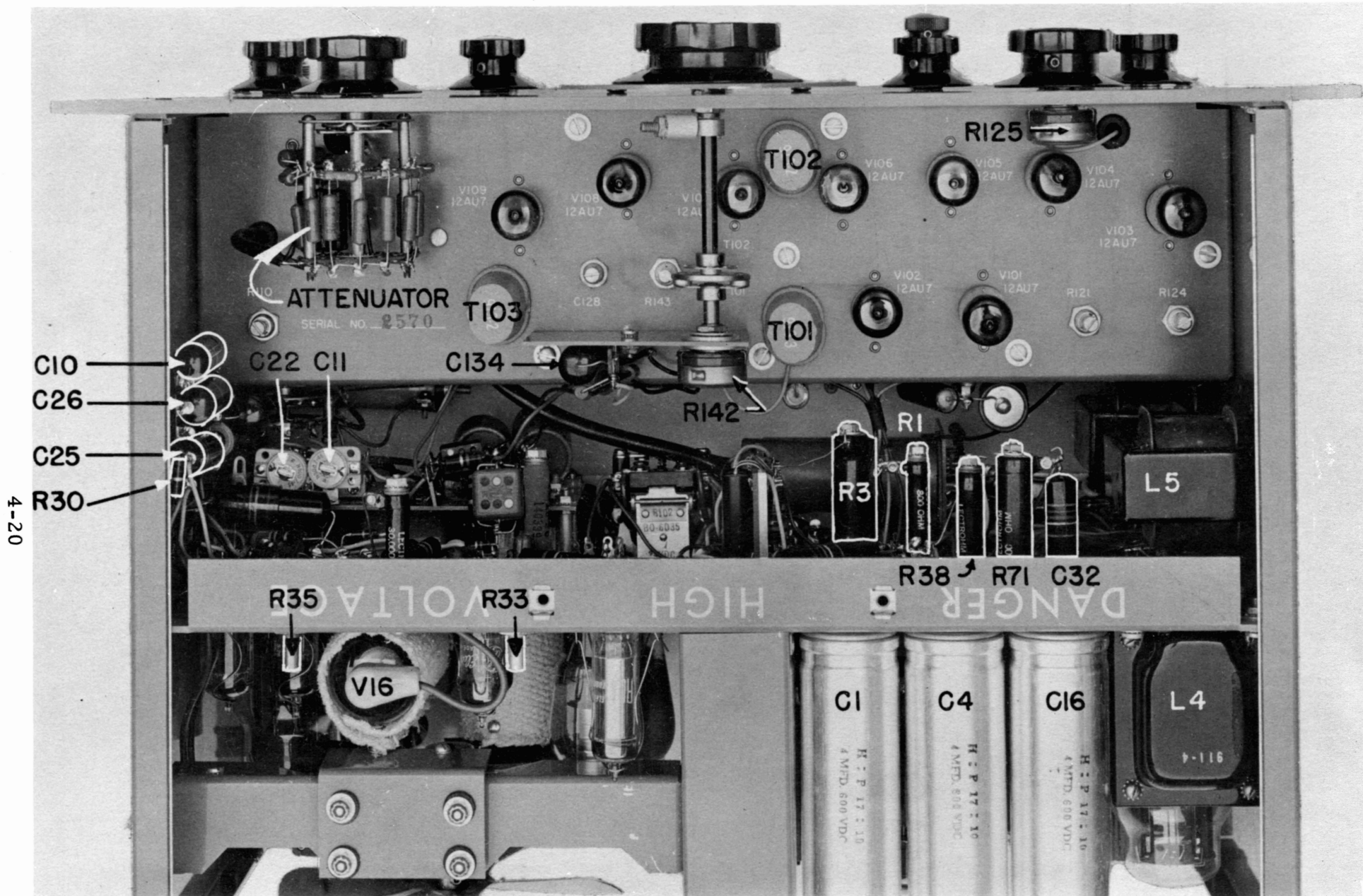

4-20

Fig. 4-1 Pulse Generator, Typical Top View, Cover Removed

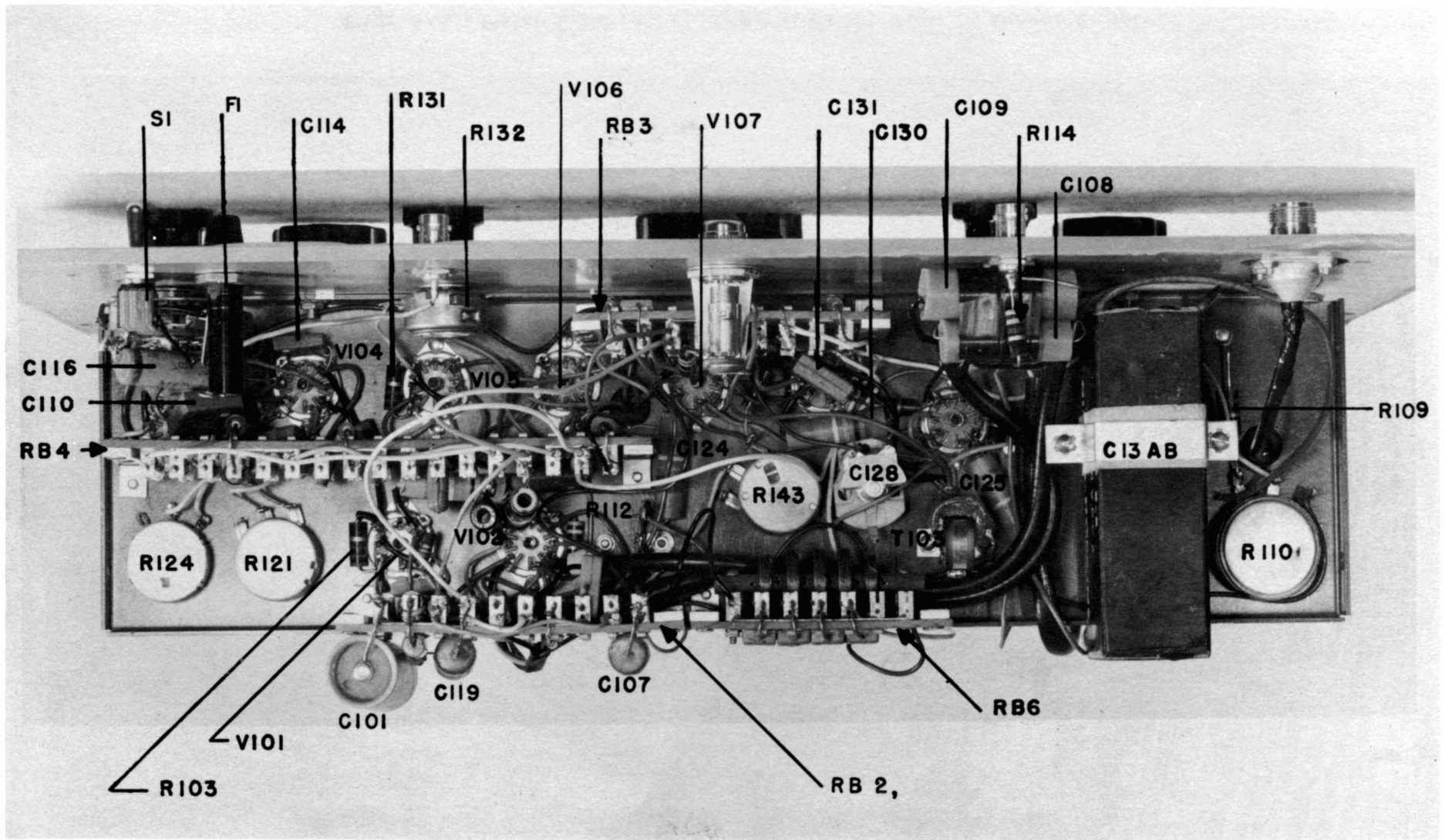

Fig. 4-2 Pulse Generator, Typical Bottom View, Pulse Timing Section

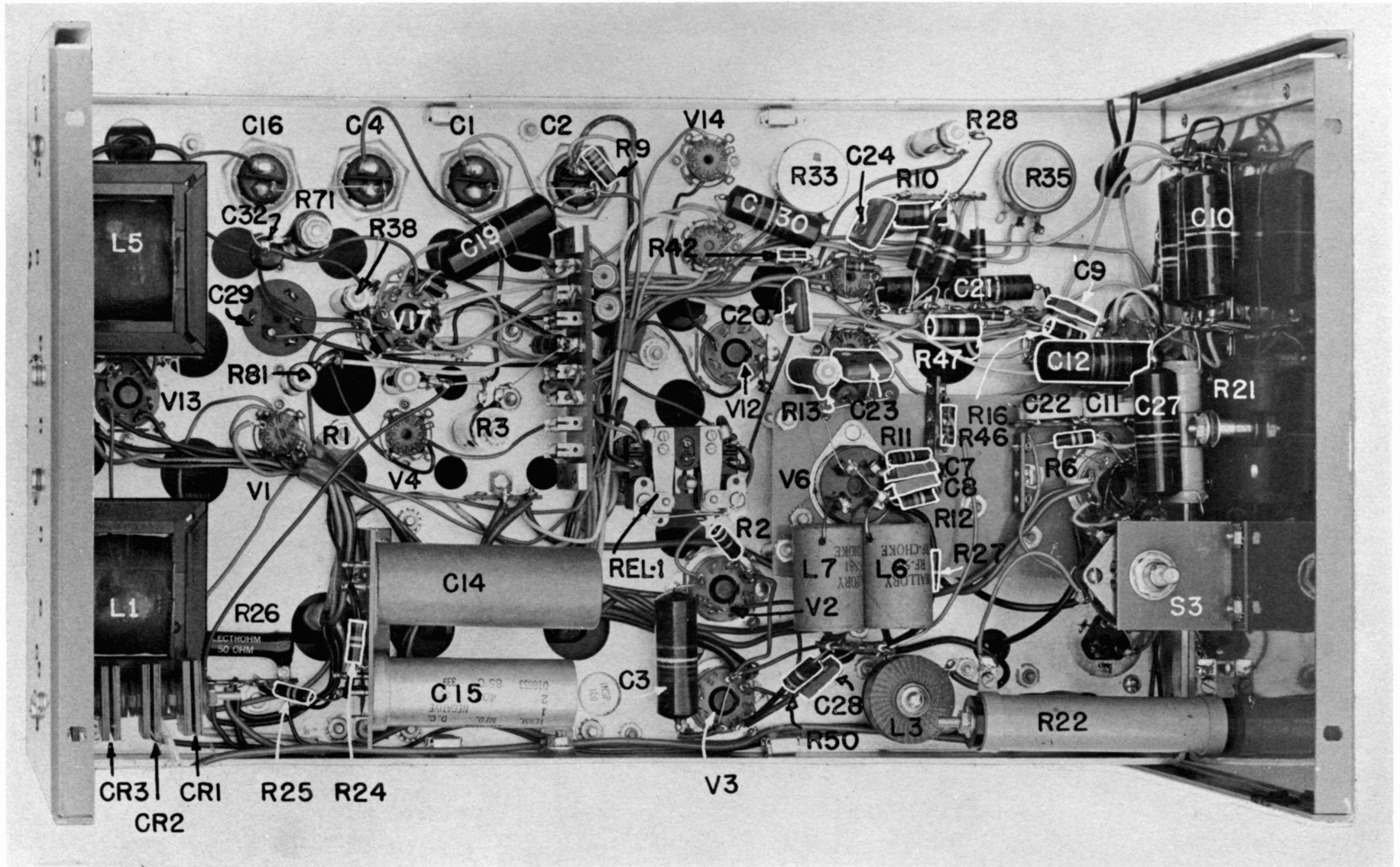

Fig. 4-3 Pulse Generator, Typical Front View of Power Supply and Pulse Generating Sections (Removed)

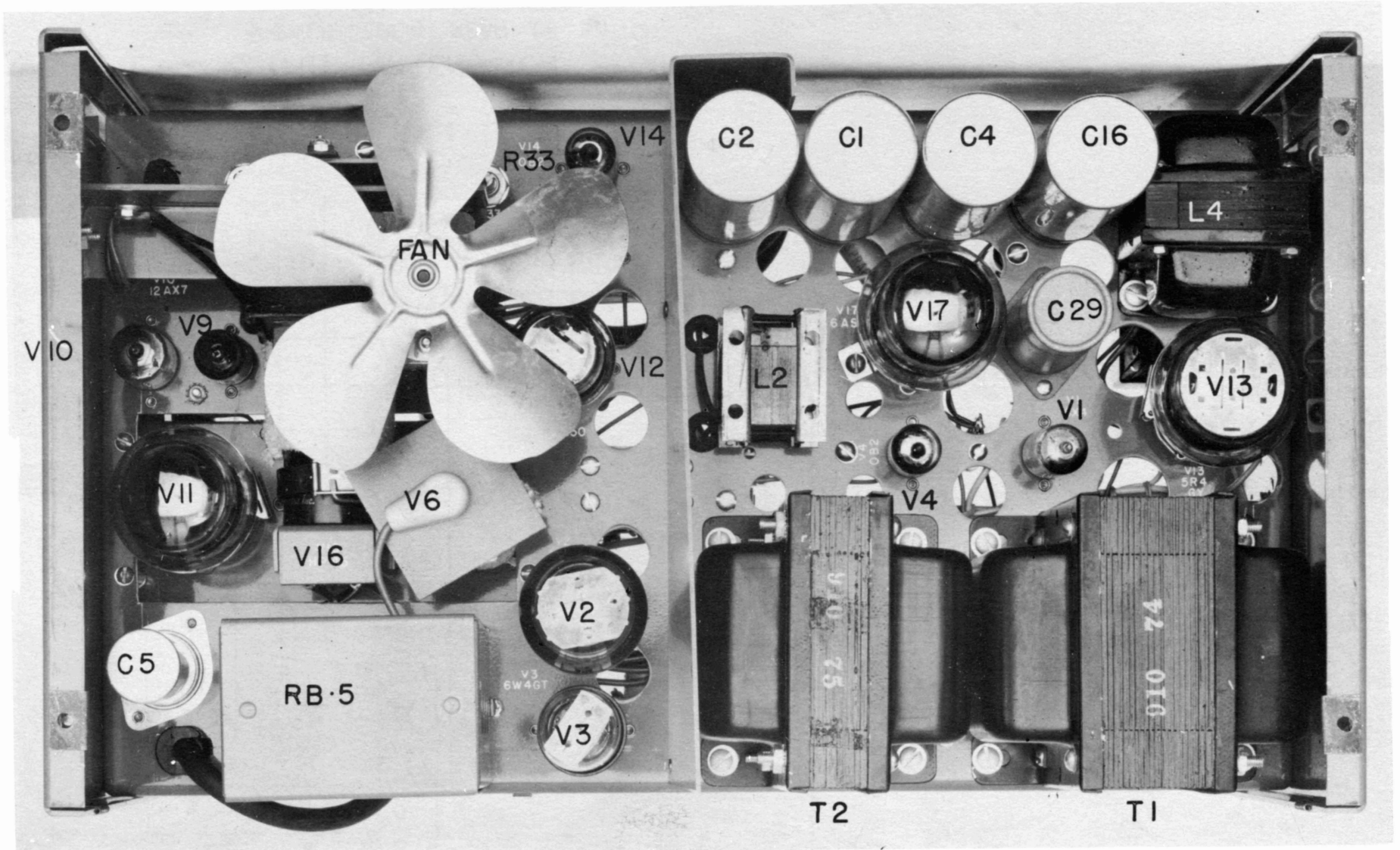

Fig. 4-4 Pulse Generator, Typical Rear View of Power Supply and Pulse Generating Sections (Removed)



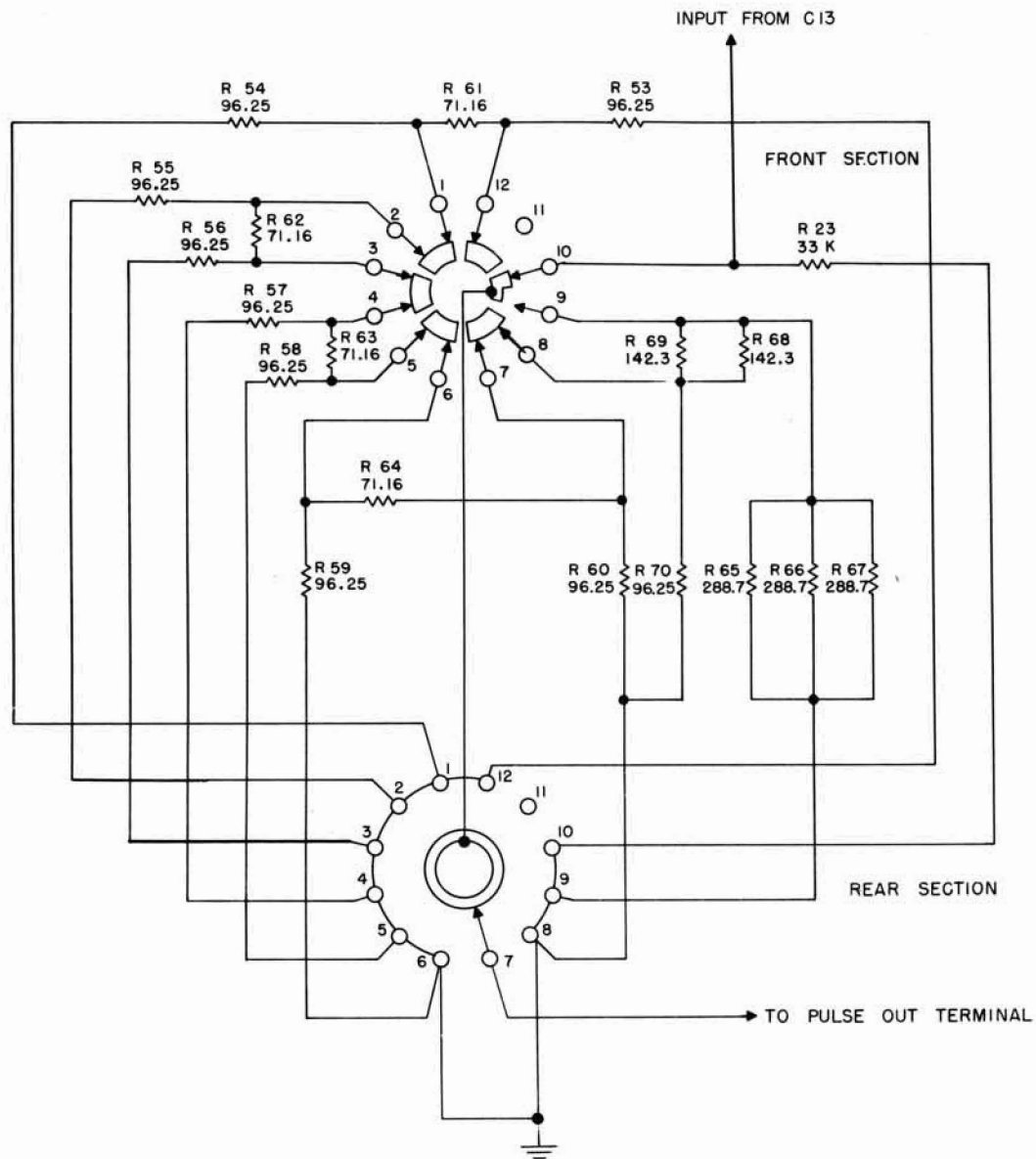
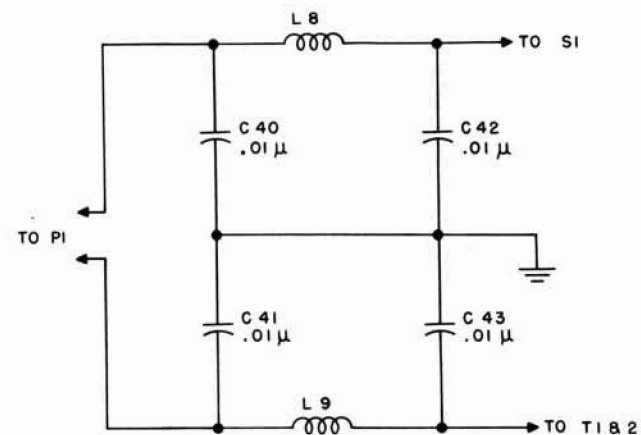

Fig. 4-5 OUTPUT ATTENUATOR DETAIL  
VIEWED FROM REAR OF SWITCH  
ATTENUATION - ODB.



### POWER LINE FILTER DETAIL

THE POWER LINE FILTER IS NOT REQUIRED ON INSTRUMENTS WHERE T1 AND T2 CONTAIN INTERNAL ELECTROSTATIC SHIELDS.

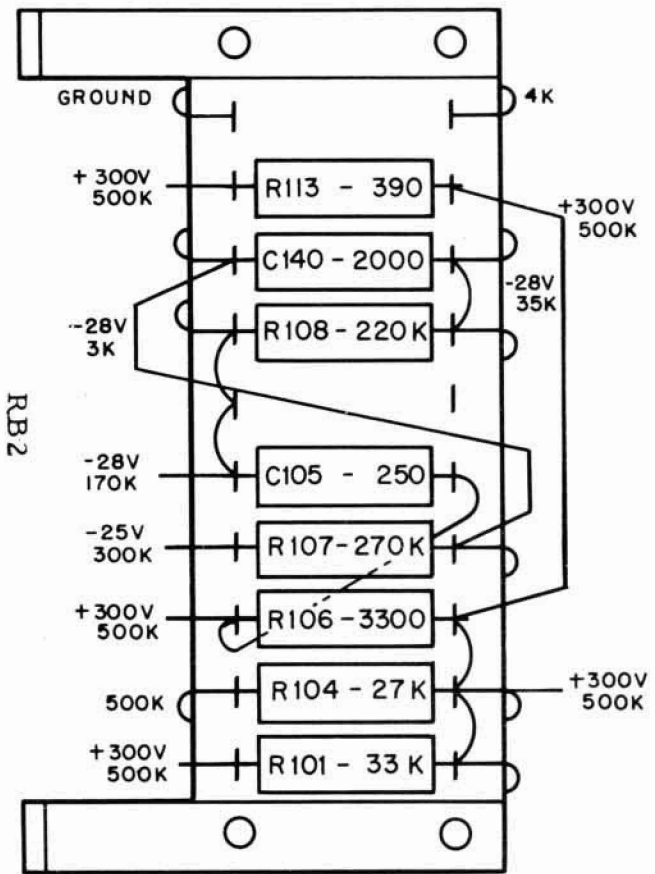
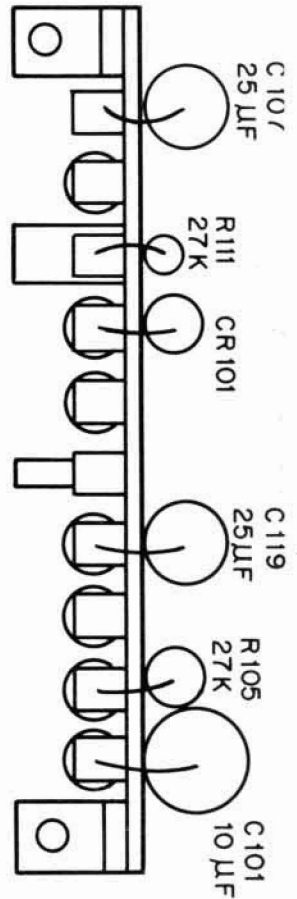
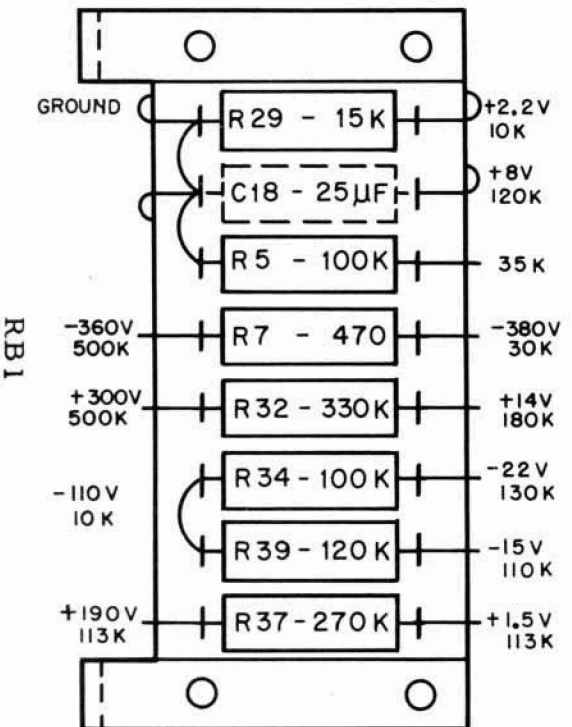
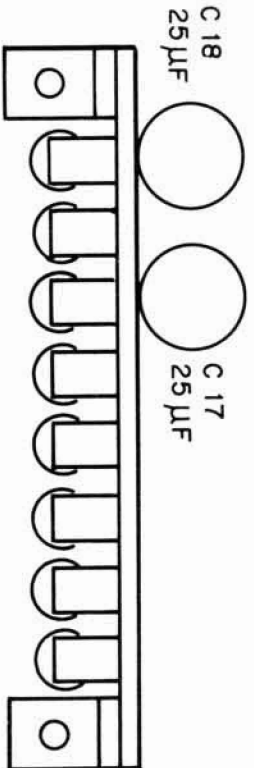
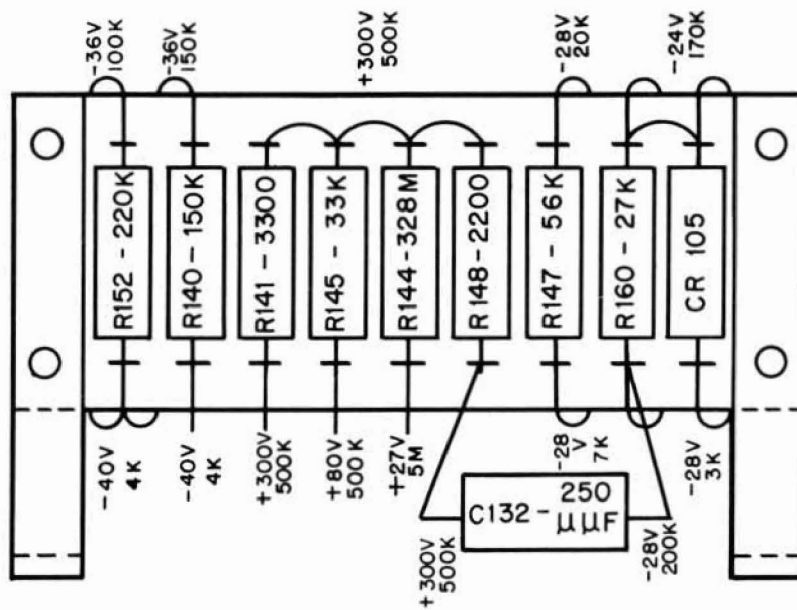
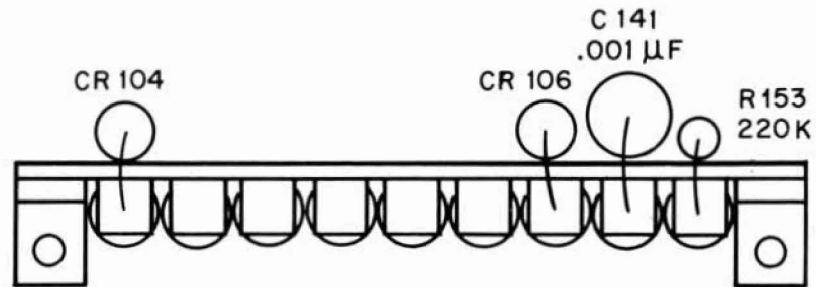
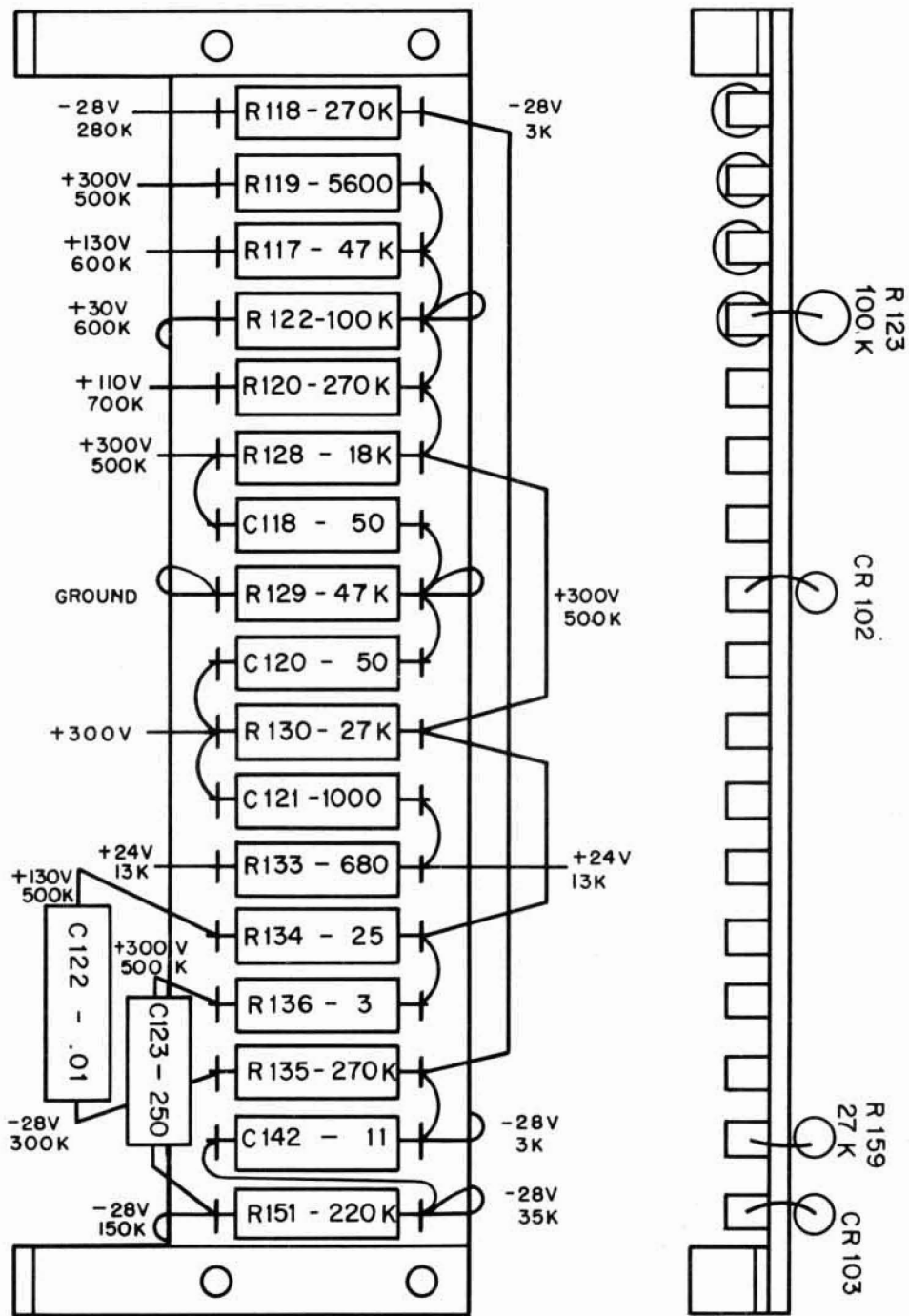

Fig. 4-6 Typical Resistor Board Details



RB3

Fig. 4-7 Typical Resistor Board Details



RB4.

Fig. 4-8 Typical Resistor Board Details

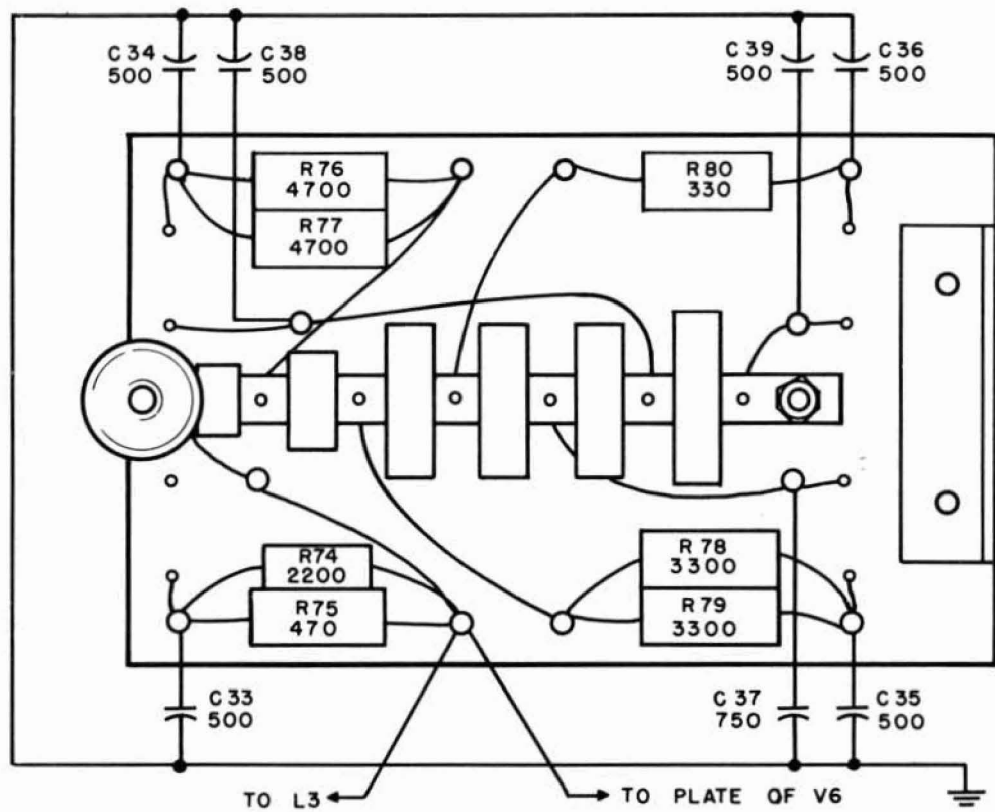

Pulse Forming Line  
RB5

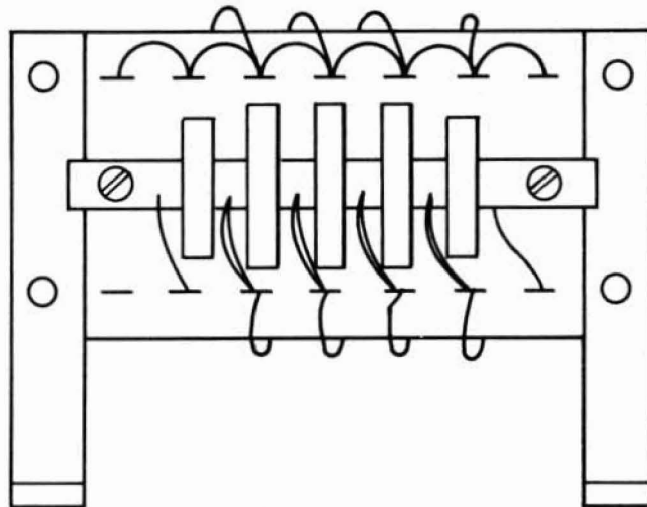
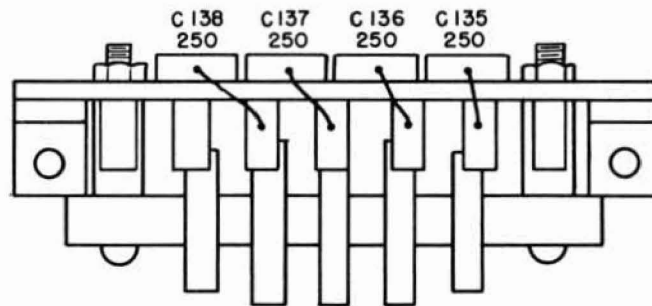

Delay Line  
RB6

Fig. 4-9 Typical Resistor Board Details

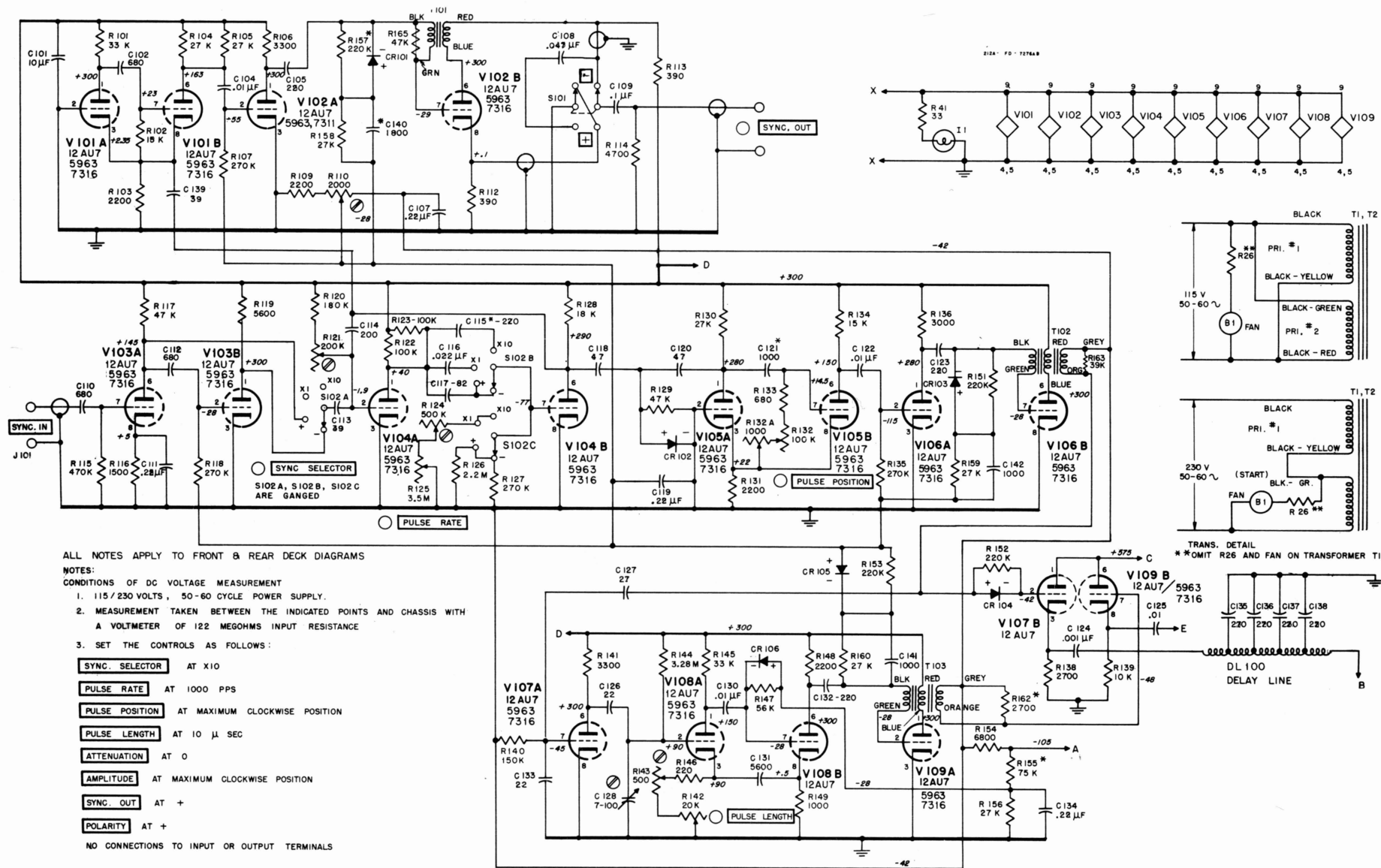

ALL NOTES APPLY TO FRONT & REAR DECK DIAGRAMS

NOTES:

CONDITIONS OF DC VOLTAGE MEASUREMENT

1. 115/230 VOLTS, 50-60 CYCLE POWER SUPPLY.
2. MEASUREMENT TAKEN BETWEEN THE INDICATED POINTS AND CHASSIS WITH A VOLTMETER OF 122 MEGOHMS INPUT RESISTANCE
3. SET THE CONTROLS AS FOLLOWS:

- SYNC. SELECTOR** AT X10
  - PULSE RATE** AT 1000 PPS
  - PULSE POSITION** AT MAXIMUM CLOCKWISE POSITION
  - PULSE LENGTH** AT 10 μ SEC
  - ATTENUATION** AT 0
  - AMPLITUDE** AT MAXIMUM CLOCKWISE POSITION
  - SYNC. OUT** AT +
  - POLARITY** AT +
- NO CONNECTIONS TO INPUT OR OUTPUT TERMINALS

ALL NOTES APPLY TO FRONT & REAR DECK DIAGRAMS

NOTES:  
CAPACITY IN  $\mu\text{F}$  UNLESS OTHERWISE NOTED.  
K = 1000 OHMS  
M = 1 MEGOHM

\* = ELECTRICAL VALUE ADJUSTED AT THE FACTORY. PART MAY BE OMITTED.  
TYPE HP45 THYRATRONS (V6, V16) HAVE PINS 2 & 4 CONNECTED INTERNALLY, AS WELL AS ON THE SOCKET.

- PANEL CONTROL
- SCREWDRIVER ADJ.
- CHASSIS

A, B, C, D, E CONNECT TO CORRESPONDING LETTERS ON FRONT DECK DIAGRAM

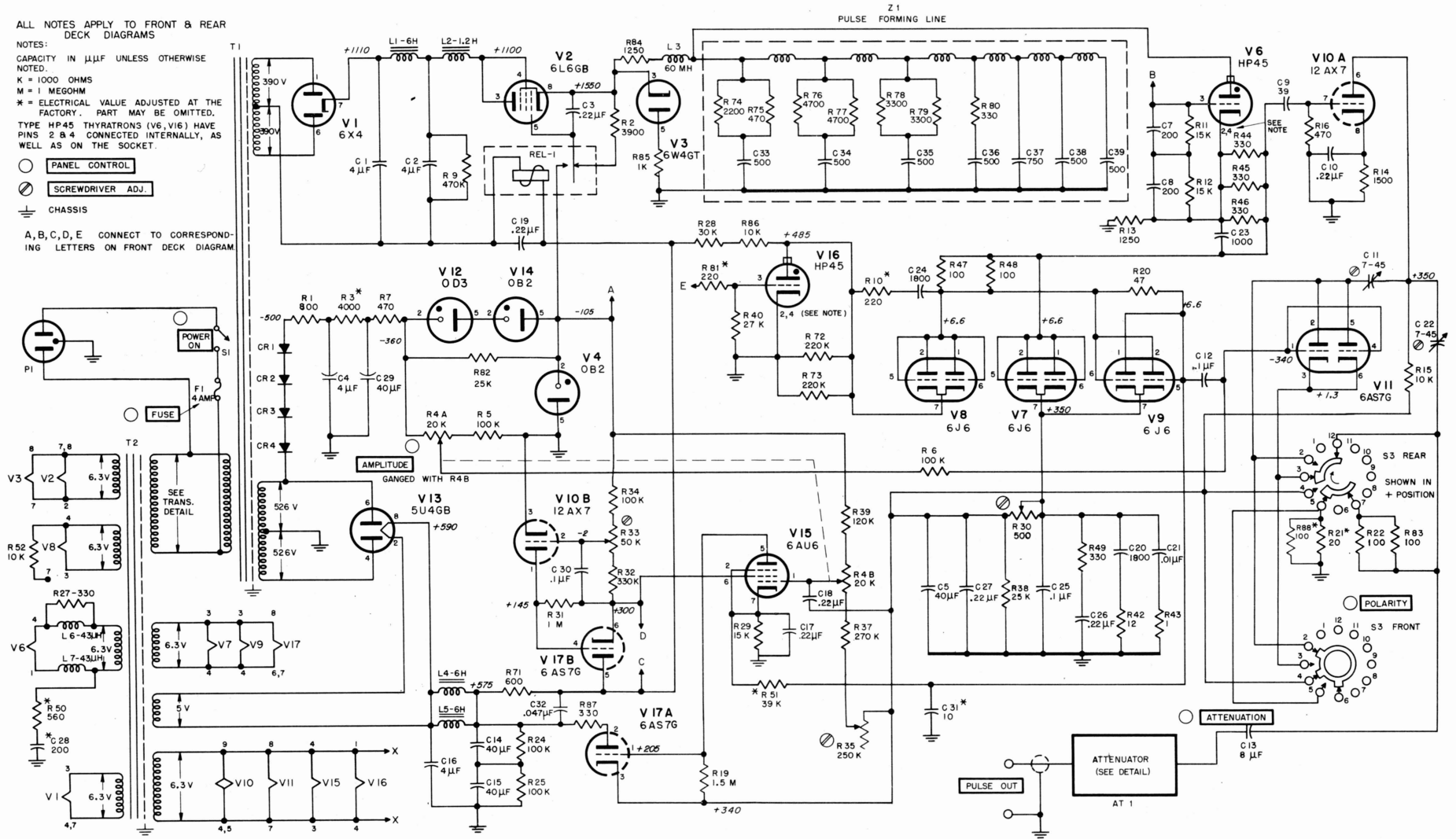

COPYRIGHT 1954 BY HEWLETT-PACKARD COMPANY  
This drawing is intended for the operator and maintenance of Hewlett-Packard equipment and is not to be used otherwise or reproduced without written consent of Hewlett-Packard Company. 212A-ND-887628

# SECTION V

## TABLE OF REPLACEABLE PARTS

### NOTE

Readily available standard-components have been used in this instrument, whenever possible. However, special components may be obtained from your local Hewlett-Packard representative or from the factory.

When ordering parts always include:

1. Ⓢ Stock Number.
2. Complete description of part including circuit reference.
3. Model number and serial number of instrument.
4. If part is not listed give complete description, function, and location of part.

If there are any corrections for the Table of Replaceable Parts they will be listed on an Instruction Manual Change sheet at the front of this manual.



**TABLE OF REPLACEABLE PARTS**

<b>CIRCUIT REF.</b>	<b>DESCRIPTION, MFR. * &amp; MFR. DESIGNATION</b>	<b>⊗ STOCK NO.</b>	<b>#</b>			
AT 1	Attenuator Assembly: output HP*	212A-19B	1			
B1	Fan Motor General Indust. Co.	314-43	1			
C1, 2	Capacitor: fixed, paper 4 μf ±10%, 1000 vdcw P*	17-54	4			
C3	Capacitor: fixed, paper dielectric, .22 μf ±10%, 400 vdcw CC*	16-48	11			
C4	Same as C1					
C5	Capacitor: fixed, electrolytic, 40 μf, 450 vdcw CC*	18-40HP	4			
C6	This circuit reference not assigned					
C7, 8	Capacitor: fixed, mica, 200 μμf ±10%, 500 vdcw V*	14-200	4			
C9	Capacitor: fixed, mica, 39 μμf ±10%, 500 vdcw V*	14-48	2			
C10	Same as C3					
C11	Capacitor: variable, ceramic dielectric, 7-45 μμf 500 vdcw L*	13-1	2			
C12	Capacitor: fixed, paper dielectric, 0.1 μf ±10%, 600 vdcw CC*	16-1	2			
C13	Capacitor: fixed, paper dielectric, 8 μf ±20%, 600 vdcw P*	17-25	1			
C14, 15	Same as C5					
C16	Same as C1					
C17, 18, 19	Same as C3					
C20	Capacitor: fixed, mica, 1800 μμf ±10%, 500 vdcw Z*	14-47	3			
C21	Capacitor: fixed, paper dielectric .01 μf, ±10%, 600 vdcw CC*	16-11	5			
C22	Same as C11					
C23	Capacitor: fixed, mica, 1000 μμf ±10%, 500 vdcw V*	14-11	5			
C24	Same as C20					
C25	Same as C12					
C26, 27	Same as C3					
C28	Same as C7 Electrical value adjusted at factory					
C29	Same as C5					
C30	Capacitor: fixed, paper dielectric, 0.1 μf, ±10%, 400 vdcw CC*	16-35	1			

\* See "List of Manufacturers Code Letters For Replaceable Parts Table".

# Total quantity used in the instrument.

**TABLE OF REPLACEABLE PARTS**

<b>CIRCUIT REF.</b>	<b>DESCRIPTION, MFR. * &amp; MFR. DESIGNATION</b>	<b>⊕ STOCK NO.</b>	<b>#</b>			
C31	Capacitor: fixed, mica, 10 $\mu\text{mf}$ , $\pm 10\%$ , 500 vdcw Electrical value adjusted at factory	V*	14-10	1		
C32	Capacitor: fixed, paper dielectric, .047 $\mu\text{f}$ , $\pm 10\%$ , 600 vdcw	CC*	16-15	2		
C33 thru C36	Capacitor: fixed, mica, 500 $\mu\text{mf}$ , $\pm 5\%$ , 2500 vdcw	Z*	14-36	6		
C37	Capacitor: fixed, mica, 750 $\mu\text{mf}$ , $\pm 5\%$ , 2500 vdcw	Z*	14-37	1		
C38, 39	Same as C33					
C40 thru C100	These circuit references not assigned					
C101	Capacitor: fixed, electrolytic, 10 $\mu\text{f}$ , $\pm 50\%$ , 450 vdcw	X*	18-10	1		
C102	Capacitor: fixed, mica, 680 $\mu\text{mf}$ , $\pm 10\%$ , 500 vdcw	Z*	14-21	3		
C103	This circuit reference not assigned					
C104	Same as C21					
C105	Capacitor: fixed, mica, 220 $\mu\text{mf}$ , $\pm 10\%$ , 500 vdcw	V*	14-66	3		
C106	This circuit reference not assigned					
C107	Same as C3					
C108	Same as C32					
C109	Capacitor: fixed, paper dielectric, 0.1 $\mu\text{f}$ , $\pm 10\%$ , 600 vdcw	CC*	16-1	1		
C110	Same as C102					
C111	Same as C3					
C112	Same as C102					
C113	Same as C9					
C114	Same as C7					
C115	Capacitor: fixed, silver mica, 220 $\mu\text{mf}$ , $\pm 5\%$ , 500 vdcw Electrical value adjusted at factory	Z*	15-32	1		
C116	Capacitor: fixed, paper dielectric, .022 $\mu\text{f}$ , $\pm 10\%$ , 600 vdcw	CC*	16-12	1		
C117	Capacitor: fixed, mica, 82 $\mu\text{mf}$ , $\pm 10\%$ , 500 vdcw	V*	14-19	1		

\* See "List of Manufacturers Code Letters For Replaceable Parts Table".

# Total quantity used in the instrument.

**TABLE OF REPLACEABLE PARTS**

<b>CIRCUIT REF.</b>	<b>DESCRIPTION, MFR. * &amp; MFR. DESIGNATION</b>	<b>STOCK NO.</b>	<b>#</b>			
C118	Capacitor: fixed, mica, 47 $\mu\mu\text{f}$ , $\pm 10\%$ , 500 vdcw V*	14-67	2			
C119	Same as C3					
C120	Same as C118					
C121	Same as C23 - Electrical value adjusted at factory					
C122	Same as C121					
C123	Same as C105					
C124	Same as C23					
C125	Same as C21					
C126	Capacitor: fixed, mica, 22 $\mu\mu\text{f}$ , $\pm 10\%$ , 500 vdcw Z*	14-61	2			
C127	Capacitor: fixed, mica, 27 $\mu\mu\text{f}$ , $\pm 10\%$ , 500 vdcw V*	14-17	1			
C128	Capacitor: variable, air dielectric, 7.5 - 102.7 $\mu\mu\text{f}$ AA*	12-12	1			
C129	This circuit reference not assigned					
C130	Same as C21					
C131	Capacitor: fixed, silver mica, 5600 $\mu\mu\text{f}$ , $\pm 1\%$ , 300 vdcw A*	15-42	1			
C132	Same as C105					
C133	Same as C126					
C134	Same as C3					
C135 thru C138	Capacitor: fixed, mica, 270 $\mu\mu\text{f}$ , $\pm 10\%$ , 500 vdcw V*	14-42	4			
C139	Capacitor: fixed, mica, 39 $\mu\mu\text{f}$ , $\pm 10\%$ , 500 vdcw V*	14-48	1			
C140	Same as C20 Electrical value adjusted at factory					
C141, 142	Same as C23					
C143	This circuit reference not assigned					
CR1, 2, 3, 4	Rectifiers, selenium AA*	212-60	4			
CR5-100	These circuit references not assigned					
CR101, 103, 104, 105	Rectifier, crystal: germanium diode Transitron	212-G12	6			
CR102, CR106	Crystal, rectifier, diode BU*	212-G11A	2			

\* See "List of Manufacturers Code Letters For Replaceable Parts Table".

# Total quantity used in the instrument.

**TABLE OF REPLACEABLE PARTS**

CIRCUIT REF.	DESCRIPTION, MFR. * & MFR. DESIGNATION	⊗ STOCK NO.	#			
DL100	Pulse delay line	HP*	212A-60C	1		
DS1	Lamp, incandescent: .15 amp, 6-8V, #47	N*	211-47	1		
F1	Fuse, cartridge: 4 amp, 115V Fuse, cartridge: 2 amp, 230V	E* E*	211-46 211-16	1		
J101, 102	Receptacle, BNC, RF connector, SYNC IN, SYNC OUT	LL*	125-9	2		
L1	Reactor, filter: open frame	Paeco	911-12	2		
L2	Reactor, pulse line charging	Paeco	911-52	1		
L3	Choke, R. F., 60 $\mu$ h	HP*	522B- 60B-1	1		
L4	Same as L1					
L5	Reactor, filter: 6h, enclosed frame	Paeco	911-4	1		
L6, 7	Choke, R. F.: 43 $\mu$ h	J. E. Fast & Co.	48-6	2		
P1	Cable, power	Elec. Cords Co.	812-106	1		
R1	Resistor: fixed, wirewound, 800 ohms, $\pm$ 10%, 10 W	S*	26-6	1		
R2	Resistor: fixed, composition, 3900 ohms, $\pm$ 10%, 1 W	B*	24-3900	1		
R3	Resistor: fixed, wirewound, 4000 ohms, $\pm$ 5%, 20 W Electrical value adjusted at factory	S*	27-7	1		
R4A, B	Resistor: variable, dual, 20,000 ohms/sect.	BO*	210-68	1		
R5, 6	Resistor: fixed, composition, 100,000 ohms, $\pm$ 10%, 1 W	B*	24-100K	5		
R7	Resistor: fixed, composition, 470 ohms, $\pm$ 10%, 2 W	B*	25-470	1		
R8	This circuit reference not assigned					
R9	Resistor: fixed, composition, 470,000 ohms, $\pm$ 10%, 1 W	B*	24-470K	2		
R10	Resistor: fixed, composition, 220 ohms, $\pm$ 10%, 2 W Electrical value adjusted at factory	B*	25-220	1		
R11, 12	Resistor: fixed, composition, 15,000 ohms, $\pm$ 10%, 1 W	B*	24-15K	3		
R13	Resistor: fixed, wirewound, 1250 ohms, $\pm$ 10%, 10 W	S*	26-26	2		
R14	Resistor: fixed, composition, 1500 ohms, $\pm$ 10%, 1 W	B*	24-1500	1		

\* See "List of Manufacturers Code Letters For Replaceable Parts Table".

# Total quantity used in the instrument.

**TABLE OF REPLACEABLE PARTS**

<b>CIRCUIT REF.</b>	<b>DESCRIPTION, MFR. * &amp; MFR. DESIGNATION</b>	<b>⊕ STOCK NO.</b>	<b>#</b>			
R15	Resistor: fixed, composition, 10,000 ohms, ±10%, 1 W B*	24-10K	2			
R16	Resistor: fixed, composition, 470 ohms, ±10%, 1 W B*	24-470	1			
R17, 18	These circuit references not assigned.					
R19	Resistor: fixed, composition, 1.5 megohms, ±10%, 1 W B*	24-1.5M	1			
R20	Resistor: fixed, composition, 47 ohms, ±10%, 2 W B*	25-47	1			
R21	Resistor: fixed, film type on glass rod body, 20 ohms, ±1%, 1 W Electrical value adjusted at factory AB*	331-20	1			
R22	Resistor: fixed, 100 ohms, ±5%, 4 W AB*	334-100	2			
R23	Resistor: fixed, composition, 33,000 ohms, ±10%, 1 W B*	24-33K	3			
R24, 25	Same as R6					
R26	Resistor: fixed, wirewound, 50 ohms, ±10%, 10 W S*	26-27	1			
R27	Resistor: fixed, composition, 330 ohms, ±10%, 1 W B*	24-330	2			
R28	Resistor: fixed, wirewound, 30,000 ohms, ±5%, 10 W S*	26-12	1			
R29	Same as R11					
R30	Resistor: variable, composition, linear taper 500 ohms, ±10%, I*	210-25	1			
R31	Resistor: fixed, composition, 1 megohm, ±10%, 1 W B*	24-1M	1			
R32	Resistor: fixed, composition, 330,000 ohms, ±10%, 1 W B*	24-330K	1			
R33	Resistor: variable, composition, 50,000 ohms, ±20%, 1/2 W I*	210-18	1			
R34	Same as R5					
R35	Resistor: variable, composition, linear taper 250,000 ohms, ±10% B*	210-44	1			
R36	This circuit reference not assigned					

\* See "List of Manufacturers Code Letters For Replaceable Parts Table".

# Total quantity used in the instrument.

**TABLE OF REPLACEABLE PARTS**

CIRCUIT REF.	DESCRIPTION, MFR. * & MFR. DESIGNATION	Ⓢ STOCK NO.	#			
R37	Resistor: fixed, composition, 270,000 ohms, ±10%, 1 W B*	24-270K	2			
R38	Resistor: fixed, wirewound, 25,000 ohms, ±10%, 10 W S*	26-11	2			
R39	Resistor: fixed, composition, 120,000 ohms, ±10%, 1 W B*	24-120K	1			
R40	Resistor: fixed, composition, 27,000 ohms, ±10%, 1 W B*	24-27K	5			
R41	Resistor: fixed, composition, 33 ohms, ±10%, 1 W B*	24-33	1			
R42	Resistor: fixed, composition, 12 ohms, ±10%, 1/2 W B*	23-12	1			
R43	Resistor: fixed, wirewound, 1 ohm HP*	212A-67C	1			
R44, 45, 46	Resistor: fixed, composition, 330 ohms, ±10%, 2 W B*	25-330	4			
R47, 48	Resistor: fixed, composition, 100 ohms, ±10%, 2 W B*	25-100	3			
R49	Same as R27					
R50	Resistor: fixed, composition, 560 ohms, ±10%, 1 W Electrical value adjusted at factory B*	24-560	1			
R51	Resistor: fixed, composition, 39,000 ohms, ±10%, 1 W Electrical value adjusted at factory B*	24-39K	1			
R52	Resistor: fixed, composition, 10,000 ohms, ±10%, 1/2 W B*	23-10K	1			
R53 thru R60	Resistor: fixed, deposited carbon, 96.25 ohms, ±1%, 1/2 W NN*	33-96.25	8			
R61 thru R64	Resistor: fixed, deposited carbon, 71.16 ohms, ±1%, 1/2 W NN*	33-71.16	4			
R65, 66, 67	Resistor: fixed, deposited carbon, 288.7 ohms, ±1%, 1 W NN*	31-288.7	3			
R68, 69	Resistor: fixed, deposited carbon, 142.3 ohms, ±1%, 1 W NN*	31-142.3	2			
R70	Resistor: fixed, deposited carbon, 96.25 ohms, ±1%, 1 W NN*	31-96.25	1			
R71	Resistor: fixed, wirewound, 600 ohms, ±10%, 20 W S*	27-1	1			
R72, 73	Resistor: fixed, composition, 220,000 ohms, ±10%, 2 W B*	25-220K	2			

\* See "List of Manufacturers Code Letters For Replaceable Parts Table".

# Total quantity used in the instrument.

**TABLE OF REPLACEABLE PARTS**

<b>CIRCUIT REF.</b>	<b>DESCRIPTION, MFR. * &amp; MFR. DESIGNATION</b>	<b>Ⓢ STOCK NO.</b>	<b>#</b>			
R74	Resistor: fixed, composition, 2200 ohms, ±10%, 1 W B*	24-2200	2			
R75	Resistor: fixed, composition, 470 ohms, ±10%, 2 W B*	25-470	1			
R76, 77	Resistor: fixed, composition, 4700 ohms, ±10%, 2 W B*	25-4700	2			
R78, 79	Resistor: fixed, composition, 3300 ohms, ±10%, 2 W B*	25-3300	2			
R80	Same as R44					
R81	Resistor: fixed, composition, 220 ohms, ±10%, 1/2 W Electrical value adjusted at factory B*	23-220	1			
R82	Same as R38					
R83	Same as R22					
R84	Same as R13					
R85	Resistor: fixed, composition, 1000 ohms, ±10%, 1 W B*	24-1000	2			
R86	Resistor: fixed, wirewound, 10,000 ohms, ±10%, 10 W S*	26-10	1			
R87	Resistor: fixed, wirewound, 330 ohms, ±10%, 5 W S*	26-75	2			
R88	Same as R47					
R89 thru R100	These circuit references not assigned					
R101	Same as R23					
R102	Resistor: fixed, composition, 15,000 ohms, ±5%, 1/2 W B*	23-15K-5	1			
R103	Resistor: fixed, composition, 2200 ohms, ±10%, 1 W B*	24-2200	3			
R104, 105	Resistor: fixed, composition, 27,000 ohms, ±10%, 2 W B*	25-27K	2			
R106	Resistor: fixed, composition, 3300 ohms, ±10%, 1 W B*	24-3300	1			
R107	Resistor: fixed, composition, 270,000 ohms, ±10%, 1/2 W B*	23-270K	1			
R108	This circuit reference not assigned					
R109	Same as R103					

\* See "List of Manufacturers Code Letters For Replaceable Parts Table".

# Total quantity used in the instrument.

**TABLE OF REPLACEABLE PARTS**

<b>CIRCUIT REF.</b>	<b>DESCRIPTION, MFR. * &amp; MFR. DESIGNATION</b>	<b>Ⓢ STOCK NO.</b>	<b>#</b>			
R110	Resistor: variable, composition, 2000 ohms, ±20%, 1/4 W I*	210-14	1			
R111	This circuit reference not assigned					
R112, 113	Resistor: fixed, composition, 390 ohms, ±10%, 1 W B*	24-390	1			
R114	Resistor: fixed, composition, 4700 ohms, ±10% 1 W B*	24-4700	1			
R115	Same as R9					
R116	Resistor: fixed, composition, 1500 ohms, ±10%, 1 W B*	24-1500	1			
R117	Resistor: fixed, composition, 47,000 ohms, ±10%, 1 W B*	24-47K	2			
R118	Resistor: fixed, composition, 270,000 ohms, ±10%, 1/2 W B*	23-270K	2			
R119	Resistor: fixed, composition, 5600 ohms, ±10%, 1 W B*	24-5600	1			
R120	Resistor: fixed, composition, 180,000 ohms, ±10%, 1 W B*	24-180K	1			
R121	Resistor: variable, composition, 200,000 ohms, ±20% I*	210-19	1			
R122, 123	Resistor: fixed, composition, 100,000 ohms, ±10%, 2 W B*	25-100K	2			
R124	Resistor: variable, composition, linear taper 500,000 ohms G*	210-20	1			
R125	Resistor: variable, composition, 3.5 megohms, ±20% B*	210-81	1			
R126	Resistor: fixed, composition, 2.2 megohms, ±10%, 1 W B*	24-2.2M	1			
R127	Same as R37					
R128	Resistor: fixed, composition, 18,000 ohms, ±10%, 1 W B*	24-18K	1			
R129	Same as R117					
R130	Same as R40					
R131	Same as R103					
R132AB	Resistor: variable, carbon, dual section, front section: 100,000 ohms rear section: 1000 ohms I*	210-74	1			

\* See "List of Manufacturers Code Letters For Replaceable Parts Table".

# Total quantity used in the instrument.



**TABLE OF REPLACEABLE PARTS**

<b>CIRCUIT REF.</b>	<b>DESCRIPTION, MFR. * &amp; MFR. DESIGNATION</b>	<b>⊕ STOCK NO.</b>	<b>#</b>			
R133	Resistor: fixed, composition, 680 ohms, ±10%, 1/2 W B*	23-680	1			
R134	Resistor: fixed, wirewound, 15,000 ohms, ±10%, 10 W S*	26-25	1			
R135	Same as R118					
R136	Resistor: fixed, wirewound, 3000 ohms, ±10% S*	26-3	1			
R137	This circuit reference not assigned					
R138	Resistor: fixed, composition, 2700 ohms, ±10%, 2 W B*	25-2700	1			
R139	Same as R15					
R140	Resistor: fixed, composition, 150,000 ohms, ±10%, 1 W B*	24-150K	1			
R141	Resistor: fixed, composition, 3300 ohms, ±10%, 1 W B*	24-3300	1			
R142	Resistor: variable, composition, 20,000 ohms, ±10%, 2.25 W B*	210-70	1			
R143	Resistor: variable, composition, linear taper 500 ohms, ±10%, I*	210-25	1			
R144	Resistor: fixed, deposited carbon, 3.28 megohms, ±1%, 1 W NN*	31-3.28M	1			
R145	Same as R23					
R146	Resistor: fixed, composition, 220 ohms, ±10%, 1 W B*	24-220	1			
R147	Resistor: fixed, composition, 56,000 ohms, ±10%, 1/2 W B*	23-56K	1			
R148	Same as R74					
R149	Same as R85					
R150	This circuit reference not assigned					
R151, 152, 153	Resistor: fixed, composition, 220,000 ohms, ±10%, 1 W B*	24-220K	4			
R154	Resistor: fixed, composition, 6800 ohms, ±10%, 1 W B*	24-6800	1			
R155	Resistor: fixed, composition, 75,000 ohms, ±5%, 1 W Electrical value adjusted at factory B*	24-75K-5	1			
R156	Resistor: fixed, composition, 27,000 ohms, ±10%, 1 W B*	24-27K	1			

\* See "List of Manufacturers Code Letters For Replaceable Parts Table".  
# Total quantity used in the instrument.

TABLE OF REPLACEABLE PARTS

CIRCUIT REF.	DESCRIPTION, MFR. * & MFR. DESIGNATION	STOCK NO.	#			
R157	Same as R151 Electrical value adjusted at factory					
R158, 159, R160	Same as R40					
R161	Same as R87					
R162	Resistor: fixed, composition, 2700 ohms, ±10%, 1 W Electrical value adjusted at factory	B* 24-2700	1			
R163	Resistor: fixed, composition, 39,000 ohms, ±10%, 1/2 W	B* 23-39K	1			
R164	This circuit reference not assigned					
R165	Resistor: fixed, composition 15,000 ohms, ±10%, 1/2 W Electrical value adjusted at factory	B* 23-15K	1			
REL 1	Relay: DPDT, 24v dc	HP* 212A-60E	1			
S1	Switch, toggle: SPST	D* 310-11	1			
S2	This circuit reference not assigned					
S3	Switch, rotary: Polarity	W* 310-80	1			
S4-S100	These circuit references not assigned					
S101	Switch, toggle: DPDT	D* 310-54	1			
S102	Sync Selector Switch Assembly: complete	HP* 212A-19A	1			
T1	Sync Selector Switch: less components	HP* 310-81	1			
T2	Transformer, power	HP* 910-74	1			
T3	Transformer, filament	HP* 910-75	1			
T3-T100	These circuit references not assigned					
T101	Transformer, pulse: 4 leads	HP* 913-3	1			
T102, 103	Transformer, pulse: 6 leads	HP* 913-2	2			
V1	Tube, electron: 6X4	ZZ* 212-6X4	1			
V2	Tube, electron: 6L6GB	ZZ* 212-6L6GB	1			
V3	Tube, electron: 6W4GT	ZZ* 212-6W4GT	1			
V4	Tube, electron: OB2	ZZ* 212-OB2	2			
V5	This circuit reference not assigned					
V6	Tube, electron: HP45	ZZ* 212-HP45	2			
V7, 8, 9	Tube, electron: 6J6	ZZ* 212-6J6	3			
V10AB	Tube, electron: 12AX7	ZZ* 212-12AX7	1			
V11	Tube, electron: 6AS7G	ZZ* 212-6AS7G	2			
V12	Tube, electron: OD3	ZZ* 212-OD3	1			
V13	Tube, electron: 5U4GB	ZZ* 212-5U4GB	1			
V14	Same as V4					
V15	Tube, electron: 6AU6	ZZ* 212-6AU6	1			

\* See "List of Manufacturers Code Letters For Replaceable Parts Table".

# Total quantity used in the instrument.

**TABLE OF REPLACEABLE PARTS**

CIRCUIT REF.	DESCRIPTION, MFR. * & MFR. DESIGNATION	⊗ STOCK NO.	#			
V16	Same as V6					
V17A, B	Same as V11					
V18 thru V100	These circuit references not assigned					
V101 thru V109	Tube, electron: 12AU7, 5963, or 7316	ZZ*	212-7316	9		
Z1	Pulse forming line	HP*	212A-60D	1		
	<u>MISCELLANEOUS</u>					
	Cable, pulse out, complete	HP*	212A-16B	1		
	Coupler, flexible	AK*	150-1	1		
	Connector, R. F. receptacle: type N PULSE OUT	LL*	125-UG58/U	1		
	Fan blade	BO*	314-44	1		
	Filter, power line	HP*	212A-95A	1		
	Fuseholder	T*	140-16	1		
	Indicator Light	II*	145-2	1		
	Insulator, standoff	AI*	34-1	2		
	Insulator plate, bakelite 2 x 2 x 3/32" for horizontally mounted HP45 tube	HP*	212A-41	1		
	Knob: ATTENUATOR DB, POLARITY, SYNC SELECTOR	HP*	G-74N	3		
	Knob: PULSE POSITION	HP*	G-74B	1		
	Knob: AMPLITUDE, PULSE RATE	HP*	G-74K	2		
	Knob: PULSE POSITION, (skirted)	HP*	G-74L	1		
	Knob: PULSE LENGTH	ZZ*	G-74Z	1		
	Motor Assembly	HP*	212A-97	1		
	Reactor Assembly: audio, 1, 2h	HP*	212A-95C	1		
	Shield, for HP45 tube, asbestos, 3" long	HP*	212A-6A	1		
	Shock mounts for fan Berry Cont. Inc.		149-18	1		
	Switch, attenuator: (less components)	W*	310-79	1		
	Window, dial	HP*	M-2	1		

\* See "List of Manufacturers Code Letters For Replaceable Parts Table".

# Total quantity used in the instrument.



# MANUAL CHANGES

MODEL 212A

PULSE GENERATOR

ERRATA:

R165: Change to resistor, fixed, composition, 15,000 ohms  
 $\pm 10\%$ ,  $\frac{1}{2}$  W; -hp- Stock No. 23-15K, Mfr., B

